

RoHS Compliant

REV	MODIFICATION	DATE	DRAW
A2	Release To ECN20110502	2011.05.05	Ivy
A3	Release To ECN20130306	2013.03.12	Seven
A4	Release To ECN20160301	20160302	Michelle

Specification

- Current Rating: 1A AC
- Voltage Rating: 100V AC
- Contact Resistance: 30mΩ Max.
- Insulation Resistance: 500MΩ Min. At DC100V Δ A3
- Dielectric Withstanding Voltage: AC500V/Minute
- Operating Temperature: -35°C~+85°C

Material:

- Housing: High Temperature Thermoplastic UL94V-0
- Tab: Copper Alloy T=0.40mm
- Contact Pin: Copper Alloy T=0.30mm

Finish:

- Housing: See P/N Option
- Tab: Tin Plated Over Nickel
- Contact Pin: See P/N Option

Part No.: AS07803 XX X X X 1

No. Of Pin	Packing
20,25,30	1:T&R ; 4:Tube

	Housing Material	Plating
5:HTN	UL94V-0 Natural None H.F	1:Bright Tin Plated Over Ni.
K:HTN	UL94V-0 Natural H.F	2:Matte Tin Plated Over Ni.
W:HTN	UL94V-0 Black H.F	3:Gold Flash Over Ni.

PIN	DIM.A	DIM.B	DIM.C	DIM.D
20	23.75	28.95	29.95	30.55
25	30.00	35.20	36.20	36.80
30	36.25	41.45	42.45	43.05

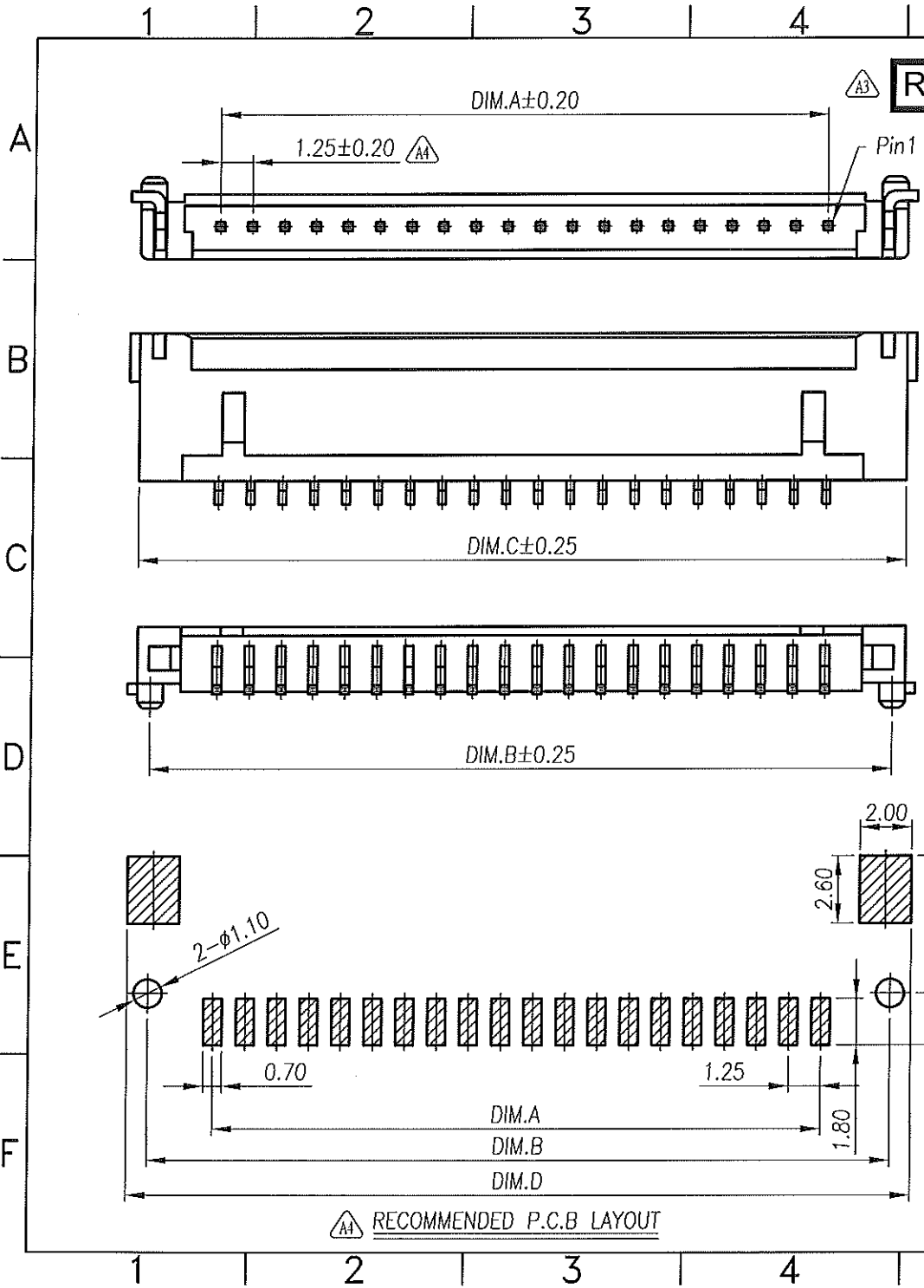



金上達科技股份有限公司

GOLDENSUND TECHNOLOGY CO., LTD

TOLERANCE UNLESS OTHERWISE SPECIFIED		PROJ. 	TITLE: Wire To Board Wafer 1.25mm 90° SMT With Post For 20,25,30Pin	
.x± 0.35	x'± 2'	APR. C.F.Liao 20160302	PART NO. AS07803XXXXX1	DWG NO. AS07803XXXXX1
.xx± 0.25	.x'± 1'	CHK. Abel 20160302	UNITS: mm CUSTOMER DRAWING	
.xxx± 0.15	.xx'± 0.5'	DRA. Michelle 20160302	SIZE: A4	SCALE 4:1 SHEET 1 / 2 REV A4

RoHS Compliant



REV	MODIFICATION	DATE	DRAW
A2	Release To ECN20110502	2011.05.05	Ivy
A3	Release To ECN20130306	2013.03.14	Seven
A4	Release To ECN20160301	20160302	Michelle

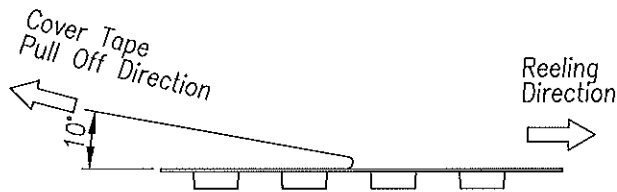
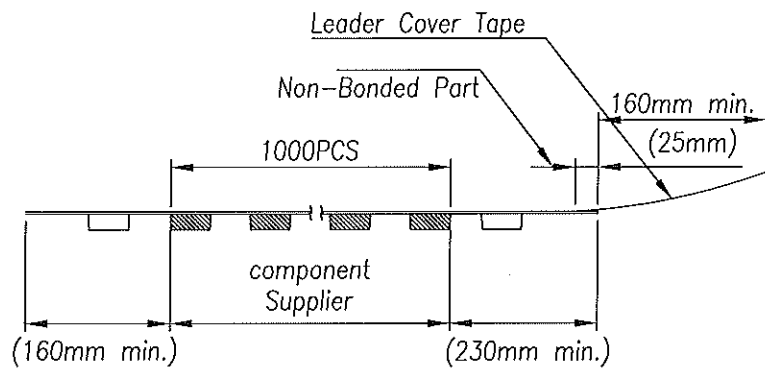
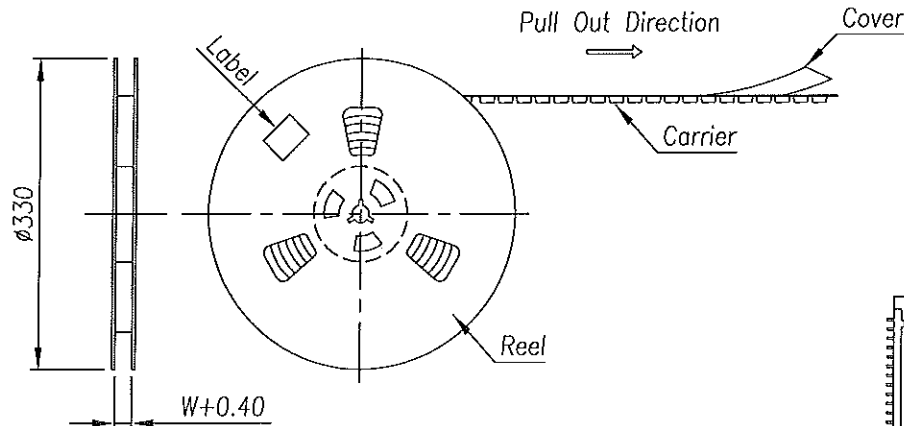

PIN NO.	W±0.30	PCS / REEL
20	44	1000
25	56	
30	56	

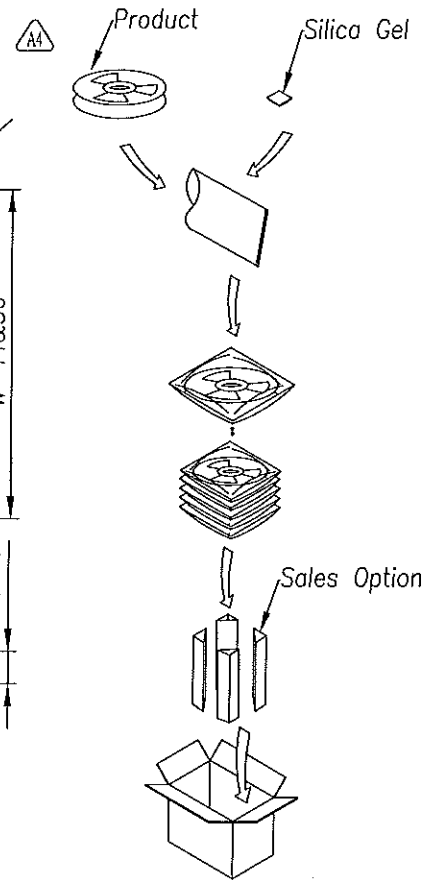
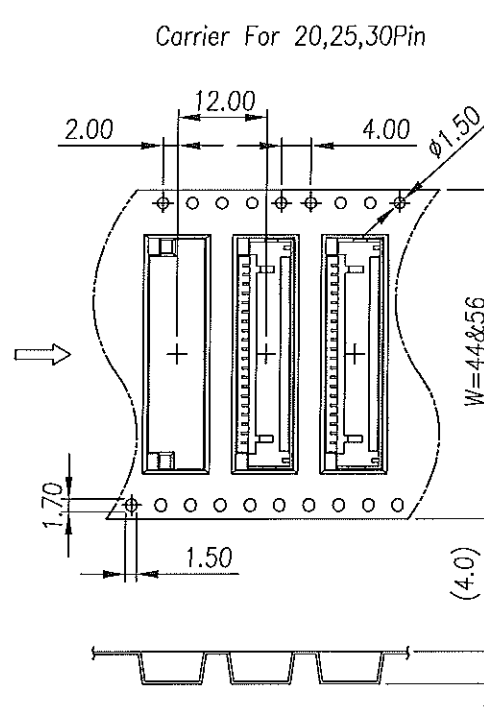

- Notes:
1. Material : PS
 2. Part No.: AS07803XXXXX1



金上達科技股份有限公司
GOLDENSUNDA TECHNOLOGY CO.,LTD

TOLERANCE UNLESS OTHERWISE SPECIFIED		PROV.	TITLE: Wire To Board Wafer 1.25mm 90° SMT With Post For 20,25,30Pin	
.x± 0.35	x.'± 2'	APR. C.F.Liao 20160302	PART NO. AS07803XXXXX1	DWG NO. AS07803XXXXX1
.xx± 0.25	.x'± 1'	CHK. Abel 20160302	UNITS: mm CUSTOMER DRAWING	
.xxx± 0.15	.xx'± 0.5'	DRA. Michelle 20160302	SIZE: A4	SCALE Free SHEET 2 / 2 REV A4