

RoHS Compliant

REV	MODIFICATION	DATE	DRAW
A0	Release To MA20130913	2013.09.17	Seven
A1	Release To ECN20130926	2013.09.26	Seven

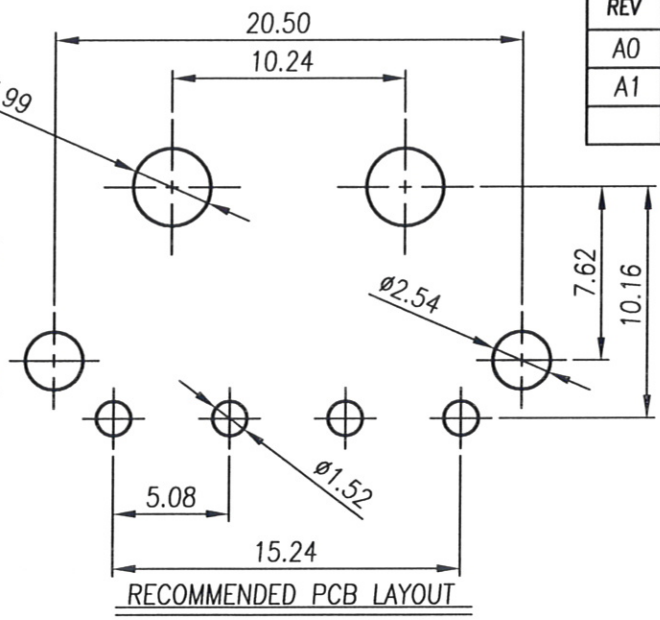
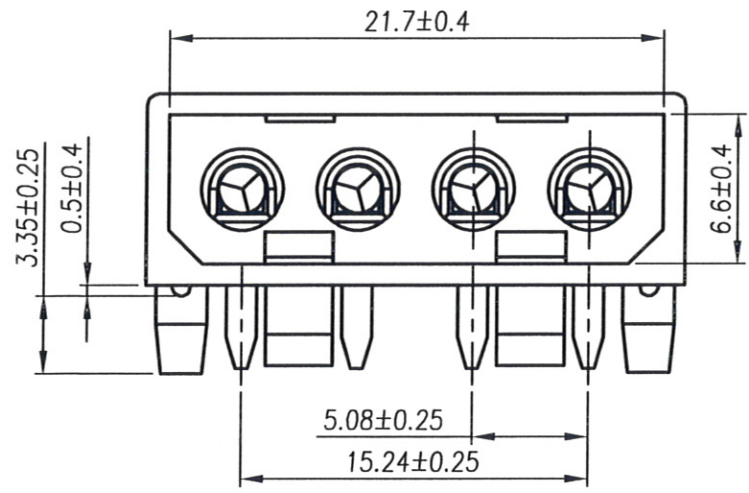

- Specification
- 1.Current Rating:6.5A
 - 2.Voltage Rating:250V AC(R.M.S)
 - 3.Contact Resistance:10mΩ Max.
 - 4.Insulation Resistance:500MΩ Min.
 - 5.Dielectric Withstanding Voltage:1500 VAC/Minute
 - 6.Operating Temperature:-40°C~+105°C

- Material:
- 1.Housing:Thermoplastic UL94V-2
 - 2.Contact Pin:Copper Alloy T=0.25mm
- Finish:
- 1.Housing:Natural
 - 2.Contact Pin:Tin Plated

Part No.:WTARM-20010- 04 0 7 1

No. Of Pin _____

04

Packing _____

7:TRAY

Plating _____

⚠ 1:Bright Tin Plated Over Cu All.

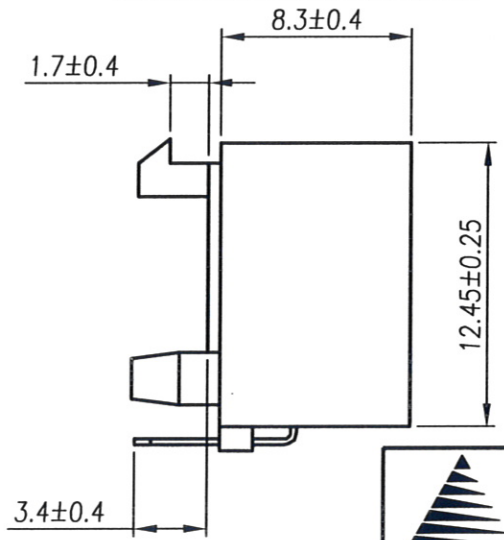
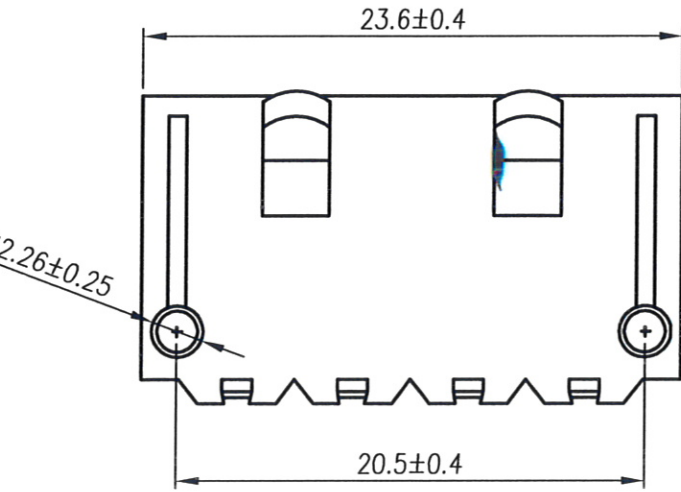

發行
102.9.26
文管中心

金上達科技股份有限公司
GOLDENSUNDA TECHNOLOGY CO.,LTD

TOLERANCE UNLESS OTHERWISE SPECIFIED		PROJ.	TITLE: Wire To Board Wafer 5.08mm 90° DIP 4P	
.x± 0.35	.x'± 2'	APR. Joy 20130926	PART NO. WTARM-20010-04071	DWG NO. WTARM-200-C-01
.xx± 0.25	.x'± 1'	CHK. Michelle 20130926	UNITS: mm	CUSTOMER DRAWING
.xxx± 0.15	.xx'± 0.5'	DRAW. Seven 20130926	SIZE: A4	SCALE 3:1
			SHEET 1 / 1	REV A1