

REV	MODIFICATION	DATE	DRAW
A1	Release To ECN20110722	2011.08.16	Ivy
A2	Release To ECN20130208	2013.02.27	Seven
A3	Release To ECN20150206	2015.02.11	Michelle

Specification

- 1.Current Rating:1A AC/DC
- 2.Voltage Rating:600V AC/DC
- 3.Contact Resistance:20mΩ Max.
- 4.Insulation Resistance:1000MΩ Min.
- 5.Dielectric Withstanding Voltage:AC1800V/Minute
- 6.Operating Temperature:-25°C~+85°C

Material:

- 1.Housing:High Temperature Thermoplastic UL94V-0
- 2.Tab:Copper Alloy T=0.30mm
- 3.Contact Pin:Copper Alloy T=0.50mm

Finish:

- 1.Housing:Nature
- 2.Tab:Matte Tin Plated Over Nickel
- 3.Contact Pin:Matte Tin Plated Over Nickel

**RoHS Compliant**

Part No.:AS017 XX 02 5 2 1 1

Series  
32:3Holes  
34:5Holes  
36:7Holes

Packing  
1:T&R

Plating A3  
2:Matte Tin Plated Over Ni

No. of Pin  
02

Housing Material  
5:HTN UL94V-0 Nature

Series	DIM.A	DIM.B	DIM.C	DIM.D
36	12.00	18.00	17.20	14.40
34	8.00	14.00	13.20	10.40
32	4.00	10.00	9.20	6.40

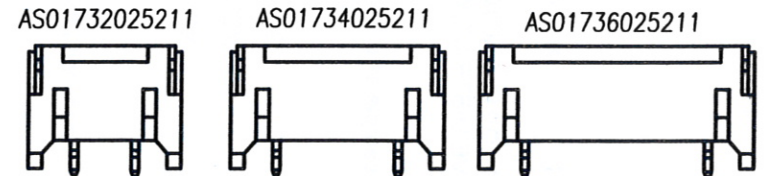

**金上達科技股份有限公司**  
GOLDENSUNDA TECHNOLOGY CO.,LTD

TOLERANCE UNLESS OTHERWISE SPECIFIED

PROJ.

TITLE: Wire To Board Wafer 4.00mm 90° SMT Single Row

APR. C.F.Liao 20150211

CHK. Abel 20150211

DRA. Michelle 20150211

PART NO. AS017XX025211

DWG NO. AS017XX025211

UNITS: mm

SIZE: A4

SCALE 5:1

SHEET 1 / 2

REV A3

CUSTOMER DRAWING

RoHS Compliant



REV	MODIFICATION	DATE	DRAW
A1	Release To ECN20110722	2011.08.16	Ivy
A2	Release To ECN20130208	2013.02.27	Seven
A3	Release To ECN20150206	2015.02.11	Michelle

A  
B  
C  
D  
E  
F

A  
B  
C  
D  
E  
F

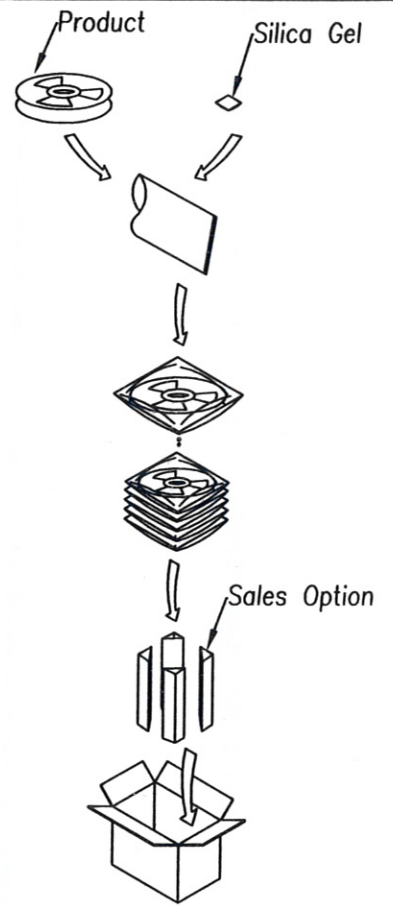
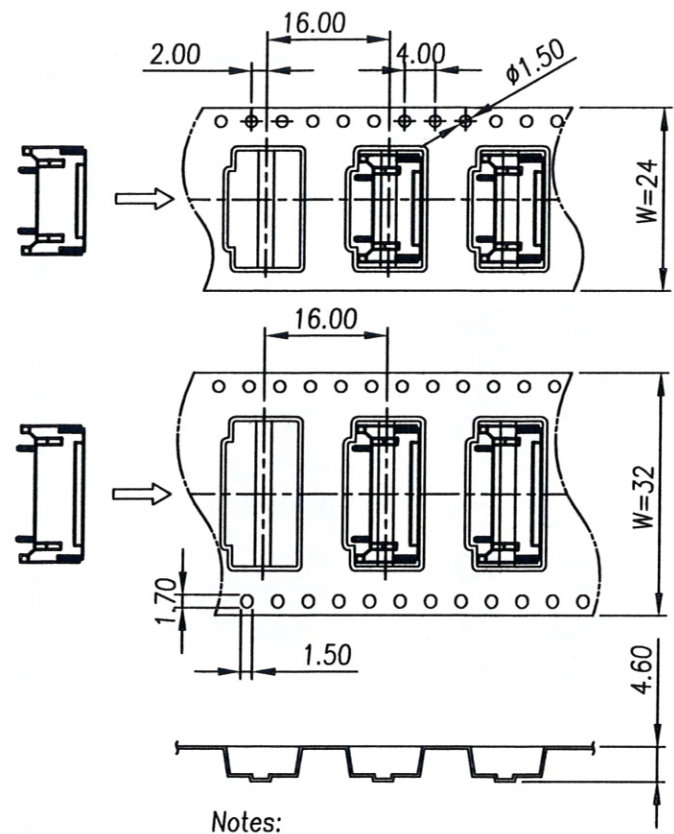
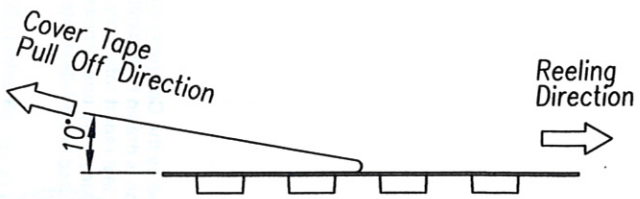
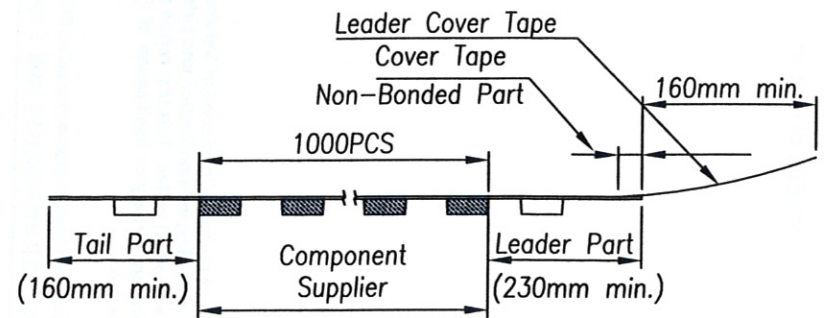
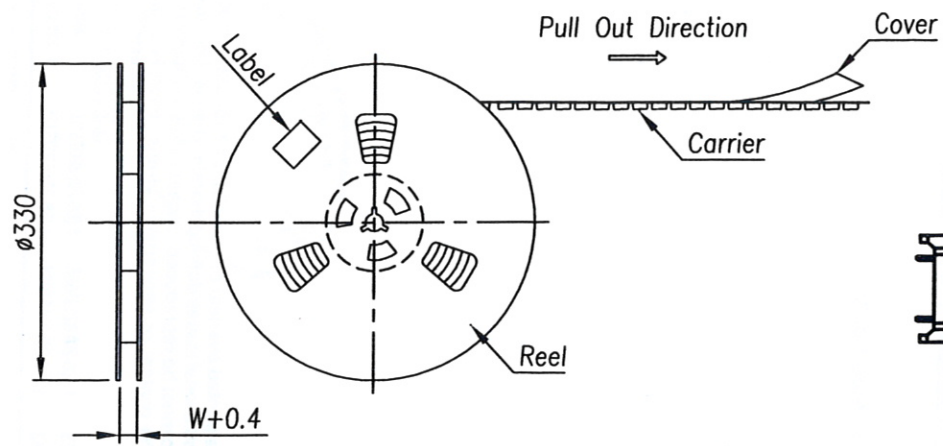

Notes:  
1. Material PS

P/N NO.	W±0.30	PCS / REEL
AS01732025211	24	1000
AS01734025211	24	
AS01736025211	32	



**金上達科技股份有限公司**  
GOLDENSUNDA TECHNOLOGY CO., LTD

TOLERANCE UNLESS OTHERWISE SPECIFIED		PROJ.	TITLE: Wire To Board Wafer 4.00mm 90° SMT Single Row	
.x± 0.35	.x'± 2'	APR. C.F.Liao 20150211	PART NO. AS017XX025211	DWG NO. AS017XX025211
.xx± 0.25	.x'± 1'	CHK. Abel 20150211	UNITS: mm	CUSTOMER DRAWING
.xxx± 0.15	.xx'± 0.5'	DRA. Michelle 20150211	SIZE: A4	SCALE Free
			SHEET 2 / 2	REV A3

1 2 3 4 5 6 7 8