

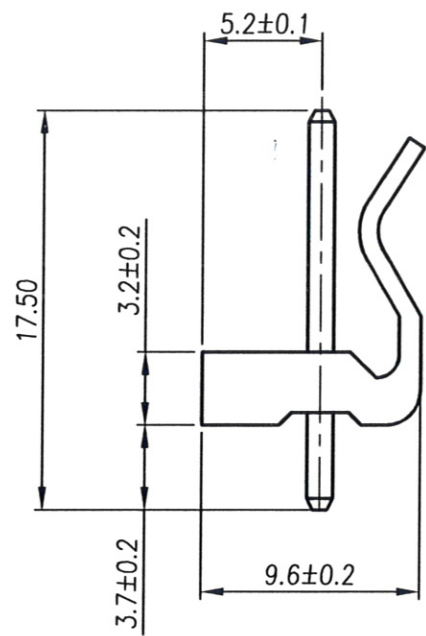

RoHS Compliant

REV	MODIFICATION	DATE	DRAW
A0	Release To Production	2009.12.15	AJ
A1	Release To ECN20130208	2013.03.07	Seven

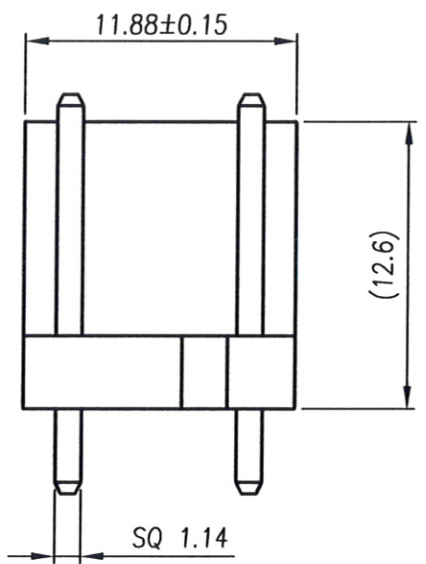
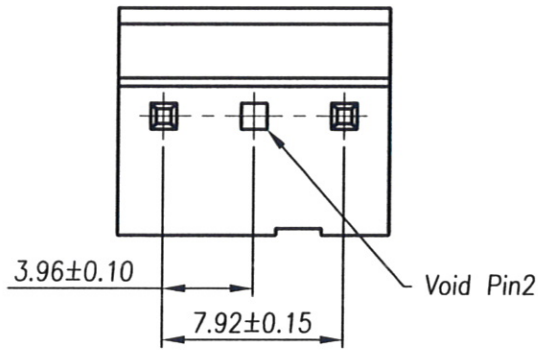

Specification

- 1.Current Rating:7A
- 2.Voltage Rating:250V AC/DC
- 3.Contact Resistance:10mΩ Max.
- 4.Insulation Resistance:1000MΩ Min. At DC 500V
- 5.Dielectric Withstanding Voltage:1500 VAC/Minute
- 6.Operating Temperature:-25℃~+85℃

Material:

- 1.Housing:Thermoplastic UL94V-2
 - 2.Contact Pin:Copper Alloy SQ Pin=1.14mm
- Finish:
- 1.Housing:Natural
 - 2.Contact Pin:Bright Tin Plated Over Nickel.

Part No.: AD02122 03 0 1 5 2

Number of Pin 03 Packing 5:Bag

Housing Material 0:NY66 UL94V-2 Natural Plating 1:Bright Tin Plated Over Ni

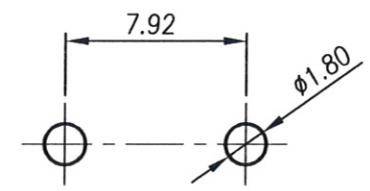

RECOMMENDED PCB LAYOUT
(Tolerance:±0.05)



金上達科技股份有限公司

GOLDENSUND TECHNOLOGY CO.,LTD

TOLERANCE UNLESS OTHERWISE SPECIFIED		PROJ.	TITLE: Wire To Board Wafer 3.96mm 180° DIP 3P Void Pin2	
.x± 0.35	x.± 2'	APR. Jay 20130307	PART NO. AD02122030152	DWG NO. AD02122030152
.xx± 0.25	.x'± 1'	CHK. Michelle 20130307	UNITS: mm	CUSTOMER DRAWING
.xxx± 0.15	.xx'± 0.5'	DRA. Seven 20130307	SIZE: A4	
		SCALE 3:1		SHEET 1 / 1
		REV A1		V