

RECOMMENDED P.C.B LAYOUT

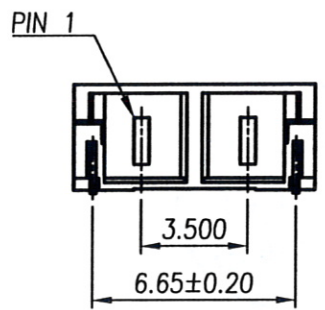

REV	MODIFICATION	DATE	DRAW
A0	Release To Production	2009.10.26	Abel
A1	Release To ECN20121207	2012.12.25	Seven
A2	Release To ECN20141208	2014.12.25	Michelle

RoHS Compliant

Specification

- 1.Current Rating:1A AC
- 2.Voltage Rating:1400V AC/DC
- 3.Contact Resistance:20mΩ Max.
- 4.Insulation Resistance:1000MΩ Min. At DC 500V
- 5.Dielectric Withstanding Voltage:AC3800V/Minute.
- 6.Operating Temperature:-25°C~+85°C

Material:

- 1.Housing:High Temperature Thermoplastic UL94V-0
- 2.Tab:Copper Alloy
- 3.Contact Pin:Copper Alloy

Finish:

- 1.Housing:Nature
- 2.Tab:Tin Plated
- 3.Contact Pin:Tin Plated

Part No.: AS0260102 B 1 X 9

Housing Material
B:NY9T UL94V-0 Nature

Packing
1:T&R
4:TUBE

Plating
1:Bright Tin Plated Over Nickel



TOLERANCE UNLESS OTHERWISE SPECIFIED		PROJ.	TITLE: Wire To Board Wafer 3.5mm 90° 2Pin SMT Single Row			
			APR. C.F.Liao 20141225		PART NO. AS0260102B1X9	
.x± 0.35	x.'± 2'	CHK. Abel 20141225	UNITS: mm		CUSTOMER DRAWING	
.xx± 0.25	.x'± 1'		DRG. Michelle 20141225		SIZE: A4	SCALE 4:1
.xxx± 0.15	.xx'± 0.5'			REV A2	V	