

REV	MODIFICATION	DATE	DRAW
A0	Release To Production	2010.06.18	Abel
A1	Release To ECN20110615	2011.06.29	Seven
A2	Release To ECN20130306	2013.03.12	Seven

Specification

RoHS Compliant

- 1.Current Rating:1A
- 2.Voltage Rating:100V AC/DC
- 3.Contact Resistance:30mΩ Max.
- 4.Insulation Resistance:500MΩ Min. At 500V
- 5.Dielectric Withstanding Voltage:AC 500V/Minute
- 6.Operating Temperature:-35°C~+85°C

Material:

- 1.Housing:High Temperature Thermoplastic UL94V-0
- 2.Contact Pin:Copper Alloy T=0.30mm
- 3.Tab:Copper Alloy T=0.40mm

Finish:

- 1.Housing:See P/N Option
- 2.Contact Pin:See P/N Option
- 3.Tab Pin:Tin Plated Over Nickel All

Part No.: AS07801 XX 5 X X 1

Number of Pin _____ Packing
20,25,30 1:T&R
4:TUBE

Housing Material _____ Plating

- 5:HTN UL94V-0 Natural
- None Halogen Free
- 1:Bright Tin Plated Over Nickel
- 2:Matte Tin Plated Over Nickel
- 3:Gold Flash Over Nickel

PIN	DIM.A	DIM.B	DIM.C
20	23.75	30.00	28.50
25	30.00	36.25	34.75
30	36.25	42.50	41.00

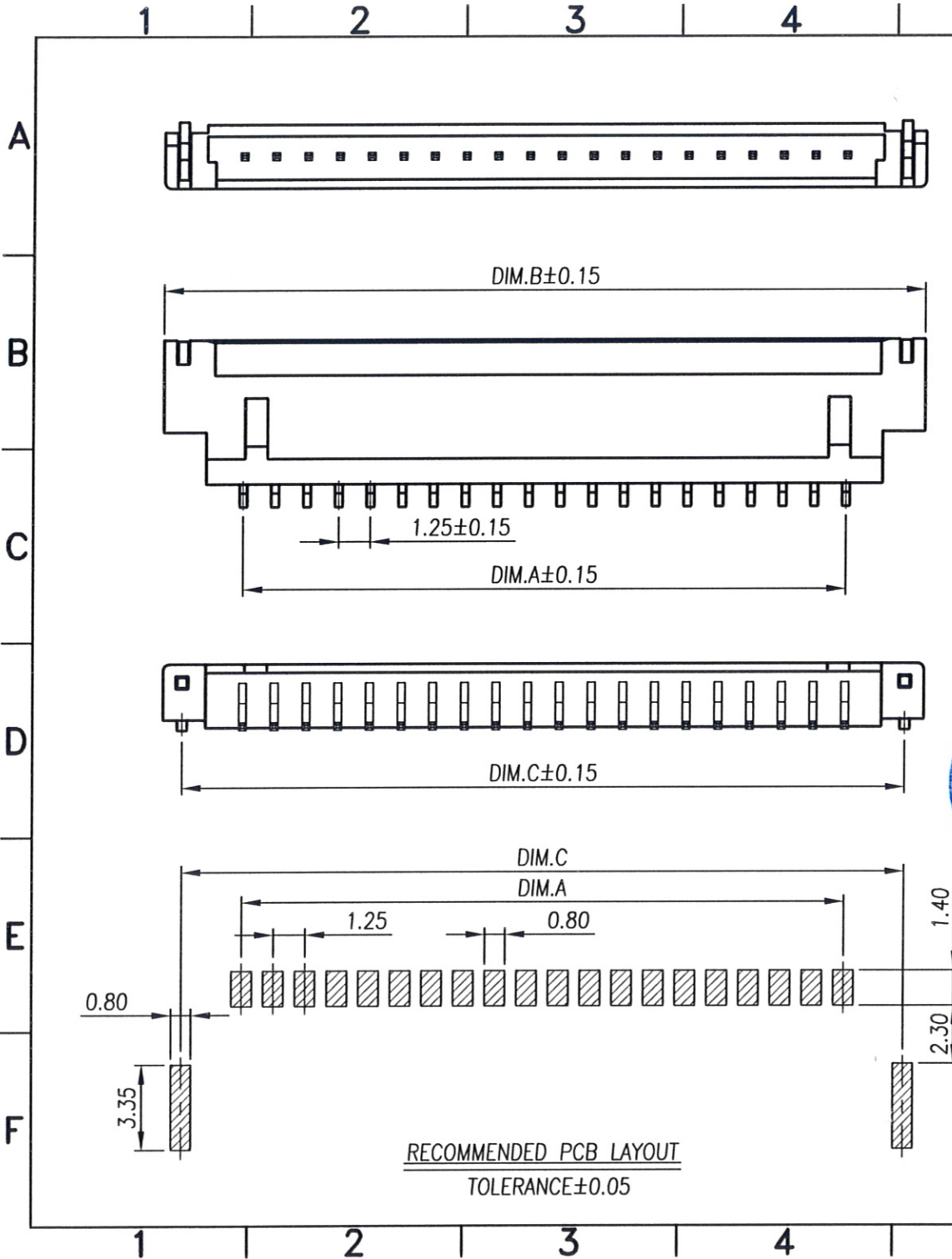

RECOMMENDED PCB LAYOUT
TOLERANCE ± 0.05

金上達科技股份有限公司
GOLDENSUNDA TECHNOLOGY CO.,LTD

TOLERANCE UNLESS OTHERWISE SPECIFIED		PROJ.	TITLE: Wire To Board Wafer 1.25mm 90° SMT W/O Post SMT	
.x± 0.35	x.'± 2'	APR. Jay 20130314	PART NO. AS07801XX5XX1	DWG NO. AS07801XX5XX1
.xx± 0.25	.x'± 1'	CHK. Michelle 20130314	UNITS: mm	CUSTOMER DRAWING
.xxx± 0.15	.xx'± 0.5'	DRA. Seven 20130314	SIZE: A4	
		SHEET 1 / 2		REV A2

RoHS Compliant



REV	MODIFICATION	DATE	DRAW
A0	Release To Production	2010.06.18	Abel
A1	Release To ECN20110615	2011.06.29	Seven
A2	Release To ECN20130306	2013.03.14	Seven

A
B
C
D
E
F

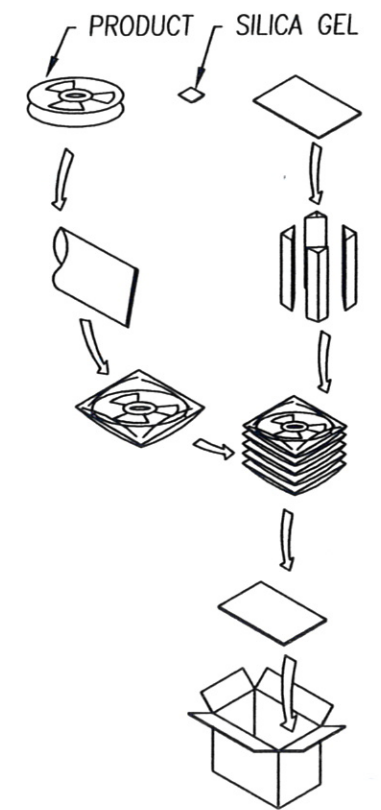
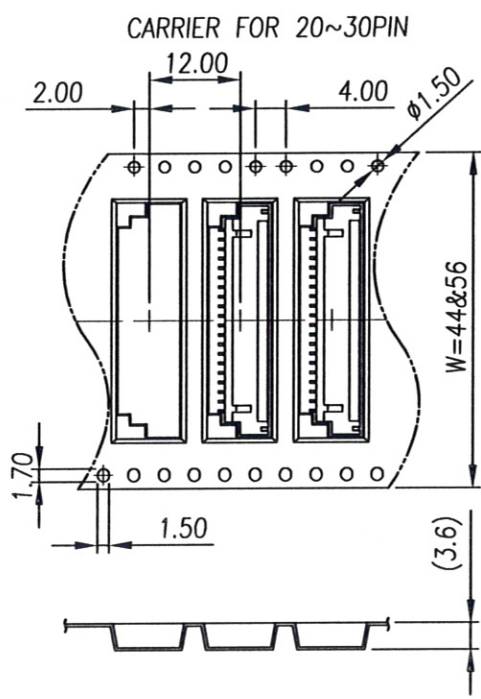
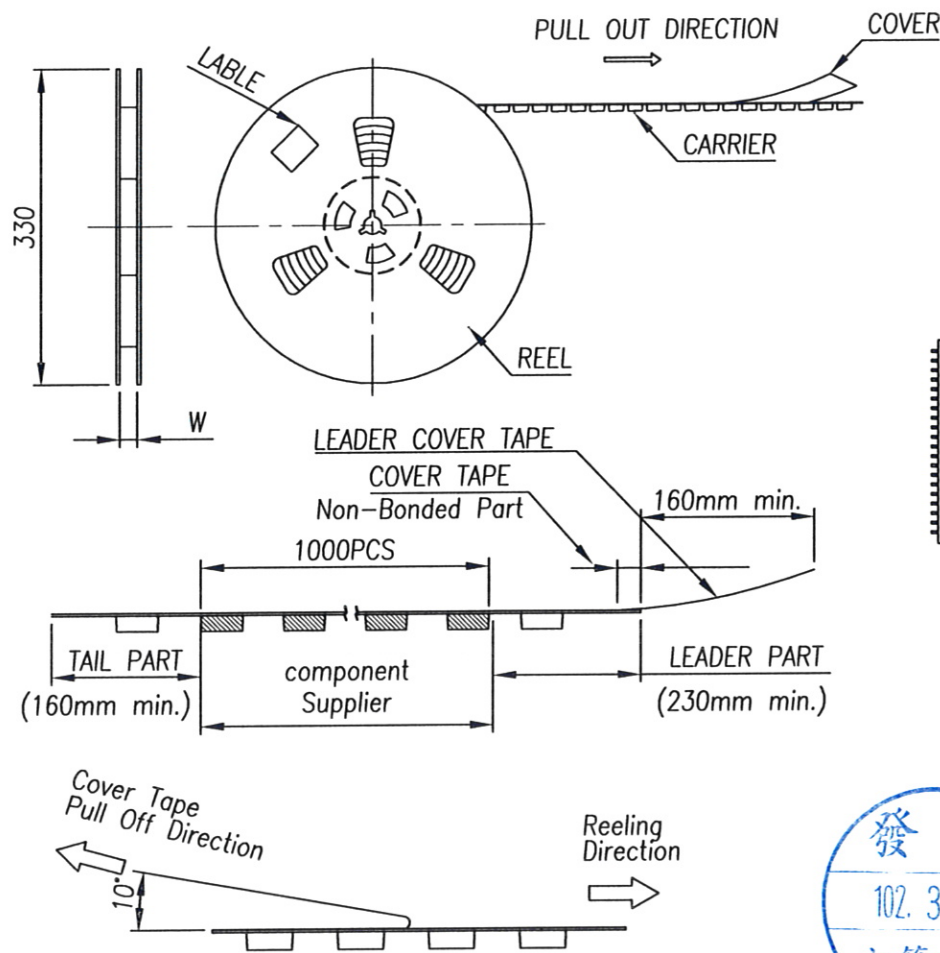

PIN NO.	W±0.30	PCS / REEL
20	44	1000
25	56	
30	56	

NOTES:
1. Material : PS
2. Part No.: AS07801XX5X11

金上達科技股份有限公司
GOLDENSUNDA TECHNOLOGY CO.,LTD

TOLERANCE UNLESS OTHERWISE SPECIFIED		PROJ.	TITLE: Wire To Board Wafer 1.25mm 90' SMT W/O Post SMT	
.x± 0.35	x:± 2'	APR. Jay 20130314	PART NO. AS07801XX5XX1	DWG NO. AS07801XX5XX1
.xx± 0.25	.x:± 1'	CHK. Michelle 20130314	UNITS: mm	
.xxx± 0.15	.xx:± 0.5'	DRA. Seven 20130314	SIZE: A4	SCALE: FREE
			SHEET 2 / 2	REV A2

CUSTOMER DRAWING

A
B
C
D
E
F

1 2 3 4 5 6 7 8