

**RoHS Compliant**

REV	MODIFICATION	DATE	DRAW
A2	Release To ECN20111106	2011.11.23	Seven
A3	Release To ECN20120901	2012.09.05	Michelle
A4	Release To ECN20121002	2012.10.05	Michelle

**Specification**  
 1.Current Rating:1A  
 2.Voltage Rating:125V AC  
 3.Contact Resistance:20mΩ Max.(Initial) 40mΩ Max.(Final)  
 4.Insulation Resistance:100MΩ Min. At 500V  
 5.Dielectric Withstanding Voltage:AC 250V/Minute  
 6.Operating Temperature:-25°C~+85°C

**Material:**  
 1.Housing:High Temperature Thermoplastic UL94V-0  
 2.Contact Pin:Copper Alloy t=0.30mm  
 3.Tab:Copper Alloy t=0.25mm

**Finish:**  
 1.Housing:See P/N Option  
 2.Contact Pin:See P/N Option  
 3.Tab:Tin Plated Over Nickel

Part No.: AS07620 XX X X X 1  
 Number of Pin: 02~15  
 Housing Material:  
 3:PA46 UL94V-0 Nature  
 5:NY6T UL94V-0 Nature  
 K:HTN UL94V-0 Nature(HF)

Packing:  
 1:T&R 4:Tube  
 Plating:  
 1:Bright Tin Plated Over Nickel  
 2:Matte Tin Plated Over Nickel  
 3:Gold Flash Over Nickel

PIN	DIM.A	DIM.B	DIM.C	DIM.D	PIN	DIM.A	DIM.B	DIM.C	DIM.D
02	1.25	3.05	4.25	7.65	09	10.00	11.80	13.00	16.40
03	2.50	4.30	5.50	8.90	10	11.25	13.05	14.25	17.65
04	3.75	5.55	6.75	10.15	11	12.50	14.30	15.50	18.90
05	5.00	6.80	8.00	11.40	12	13.75	15.55	16.75	20.15
06	6.25	8.05	9.25	12.65	13	15.00	16.80	18.00	21.40
07	7.50	9.30	10.50	13.90	14	16.25	18.05	19.25	22.65
08	8.75	10.55	11.75	15.15	15	17.50	19.30	20.50	23.90

發行  
 101.11.06  
 文管中心

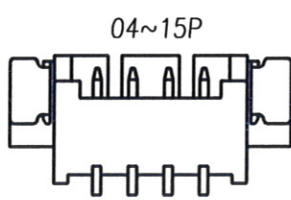
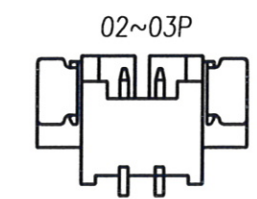

**金上達科技股份有限公司**  
**GOLDENSUNDA TECHNOLOGY CO.,LTD**

TOLERANCE UNLESS OTHERWISE SPECIFIED

.x± 0.35	.x'± 2'	PROJ.	TITLE: Wire To Board Wafer 1.25mm 90° SMT Solder Length 1.00mm
.xx± 0.25	.x'± 1'	APR. Jay 20121005	PART NO. AS07620XXXXX1 DWG NO. AS07620XXXXX1
.xxx± 0.15	.xx'± 0.5'	CHK. Seven 20121005	UNITS: mm CUSTOMER DRAWING
		DRA. Michelle 20121005	SIZE: A4 SCALE 5:1 SHEET 1 / 2 REV A4

REV	MODIFICATION	DATE	DRAW
A2	Release To ECN20111106	2011.11.23	Seven
A3	Release To ECN20120901	2012.09.05	Michelle
A4	Release To ECN20121002	2012.10.05	Michelle

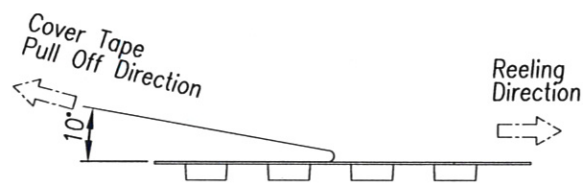
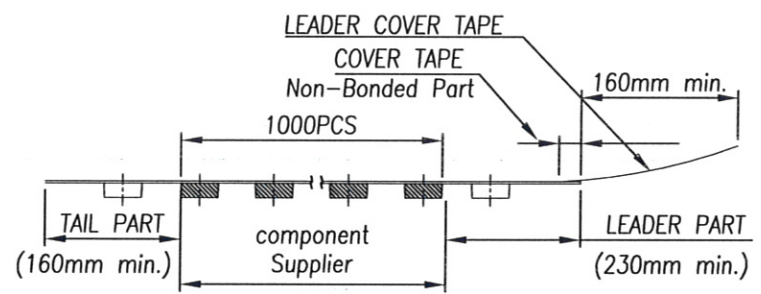
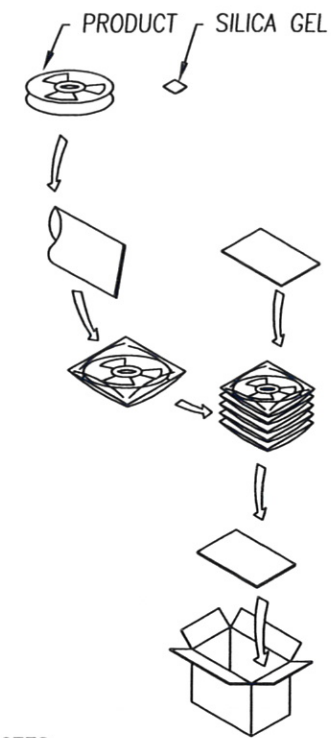
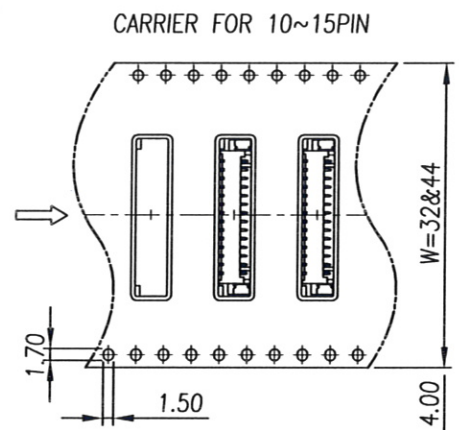
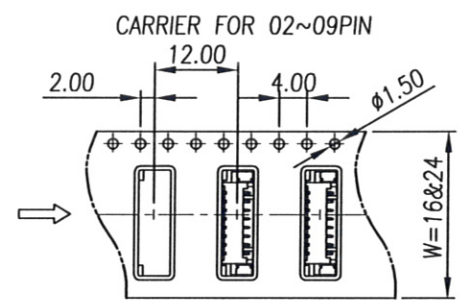
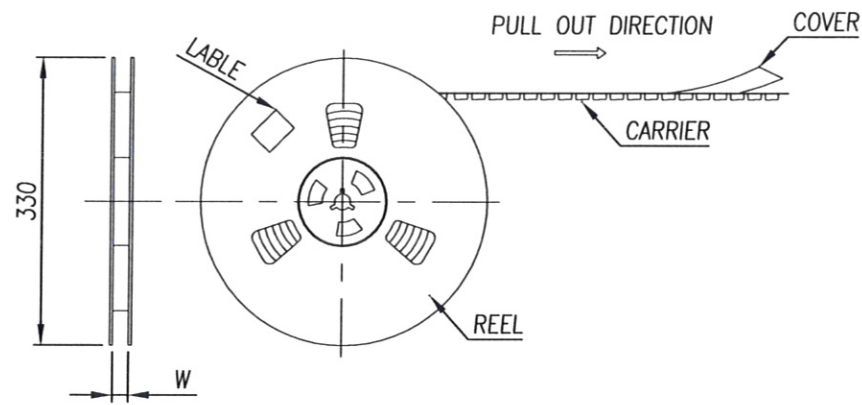

- NOTES:
1. Material : PS
  2. Part No.: AS07620XXXX11

**RoHS Compliant**

PIN NO.	W $\pm 0.30$	PCS / REEL
02 ~ 03	16	1000
04 ~ 09	24	
10 ~ 13	32	
14 ~ 15	44	



## 金上達科技股份有限公司

**GOLDENSUNDA TECHNOLOGY CO.,LTD**

TOLERANCE UNLESS OTHERWISE SPECIFIED		PROJ. 	TITLE: Wire To Board Wafer 1.25mm 90° SMT Solder Length 1.00mm	
.x $\pm$ 0.35	.x' $\pm$ 2'	APR. Jay 20121005	PART NO. AS07620XXXXX1	DWG NO. AS07620XXXXX1
.xx $\pm$ 0.25	.x' $\pm$ 1'	CHK. Seven 20121005	UNITS: mm	
.xxx $\pm$ 0.15	.xx' $\pm$ 0.5'	DRA. Michelle 20121005	SCALE FREE	
		SIZE: A4	SHEET 2 / 2	REV A4

CUSTOMER DRAWING