

RoHS Compliant

REV	MODIFICATION	DATE	DRAW
A5	Release To ECN20130306	2013.03.14	Seven
B0	Release To ECN20150613	2015.06.30	Michelle
B1	Release To ECN20150809	2015.08.28	Michelle



Specification
 1.Current Rating:1A
 2.Voltage Rating:125V AC
 3.Contact Resistance:20mΩ Max.(Initial) 40mΩ Max.(Final)
 4.Insulation Resistance:100MΩ Min. At DC 500V
 5.Dielectric Withstanding Voltage:AC250V/Minute
 6.Operating Temperature:-40°C~+85°C
 Material:
 1.Housing:High Temperature Thermoplastic UL94V-0
 2.Tab:Copper Alloy T=0.25mm
 3.Contact Pin:Copper Alloy T=0.30mm
 4.Cap:High Temperature Thermoplastic UL94V-0

Finish:
 1.Housing:See P/N Option
 2.Tab:Tin Plated Over Nickel
 3.Contact Pin:See P/N Option
 4.Cap:Natural
 Part No.: AS07600 XX X X X 1

No. Of Pin
 02~15
 Packing
 0:T&R With Cap
 1:T&R Without Cap
 3:Tube With Cap
 4:Tube Without Cap

Housing Material
 3:Nylon46 UL94V-0 Natural
 V:Nylon46 UL94V-0 Natural Dye Red
 5:Nylon6T UL94V-0 Natural
 I:HTN UL94V-0 Natural H.F Dye Black
 K:HTN UL94V-0 Natural H.F
 Plating
 1:Tab&Pin:Bright Tin Plated Over Ni
 2:Tab&Pin:Matte Tin Plated Over Ni
 3:Tab:Tin Plated Over Ni
 Pin:Gold Plated Over Ni

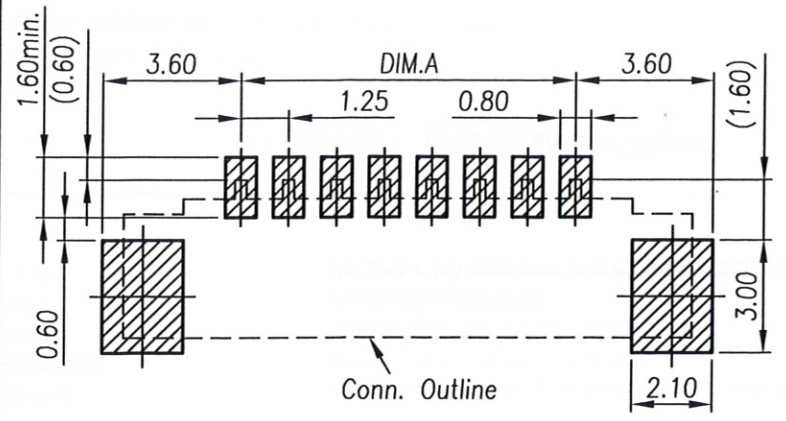
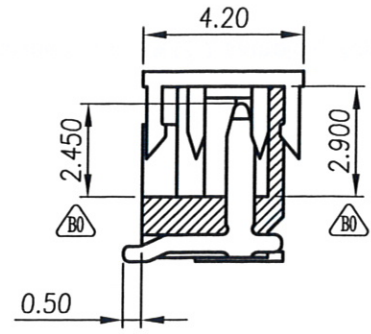
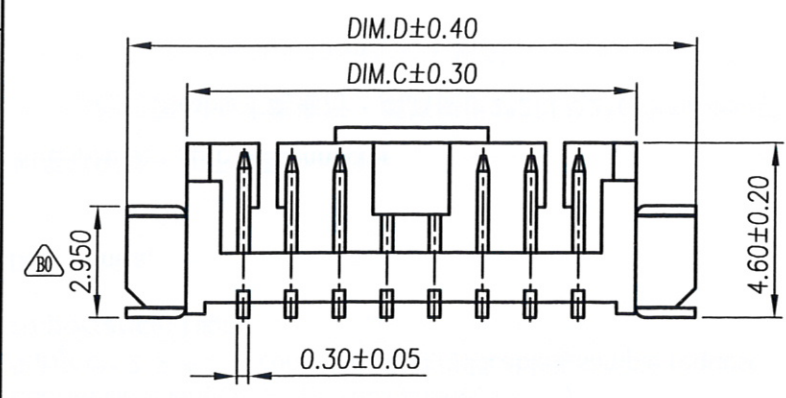
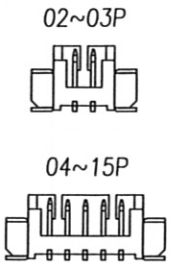
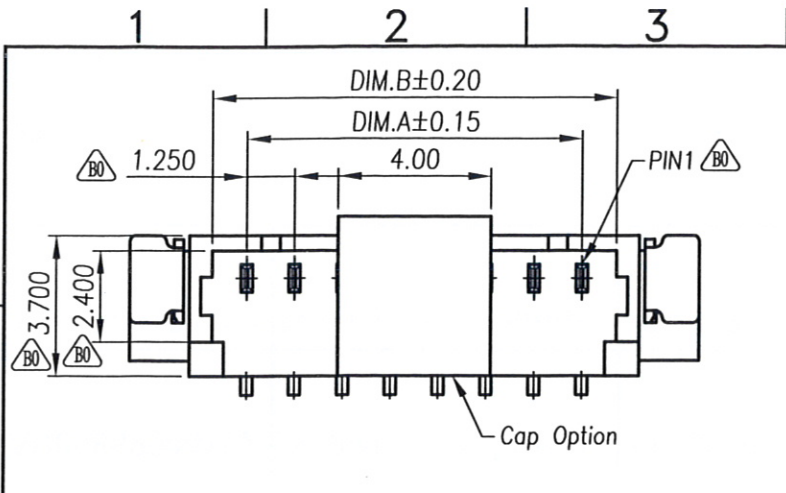

RECOMMENDED P.C.B LAYOUT

PIN	DIM.A	DIM.B	DIM.C	DIM.D
02	1.25	3.05	4.25	7.65
03	2.50	4.30	5.50	8.90
04	3.75	5.55	6.75	10.15
05	5.00	6.80	8.00	11.40
06	6.25	8.05	9.25	12.65
07	7.50	9.30	10.50	13.90
08	8.75	10.55	11.75	15.15
09	10.00	11.80	13.00	16.40
10	11.25	13.05	14.25	17.65
11	12.50	14.30	15.50	18.90
12	13.75	15.55	16.75	20.15
13	15.00	16.80	18.00	21.40
14	16.25	18.05	19.25	22.65
15	17.50	19.30	20.50	23.90

金上達科技股份有限公司
GOLDENSUNDA TECHNOLOGY CO.,LTD

TOLERANCE UNLESS OTHERWISE SPECIFIED
 PROJ. TITLE: Wire To Board Wafer 1.25mm 180° SMT Single Row

.x± 0.35 x'± 2' APR. C.F.Liao 20150828 PART NO. AS07600XXXXX1 DWG NO. AS07600XXXXX1

.xx± 0.25 .x'± 1' CHK. Abel 20150828 UNITS: mm CUSTOMER DRAWING

.xxx± 0.15 .xx'± 0.5' DRA. Michelle 20150828 SIZE: A4 SCALE 5:1 SHEET 1 / 2 REV B1

RoHS Compliant



REV	MODIFICATION	DATE	DRAW
A5	Release To ECN20130306	2013.03.14	Seven
B0	Release To ECN20150613	2015.06.30	Michelle
B1	Release To ECN20150809	2015.08.28	Michelle

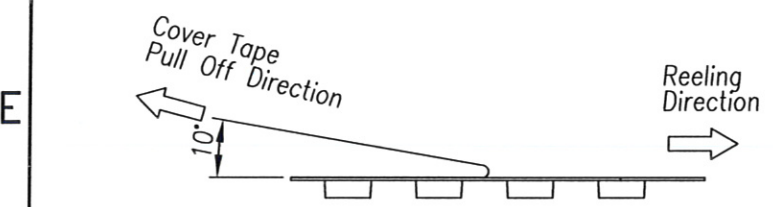
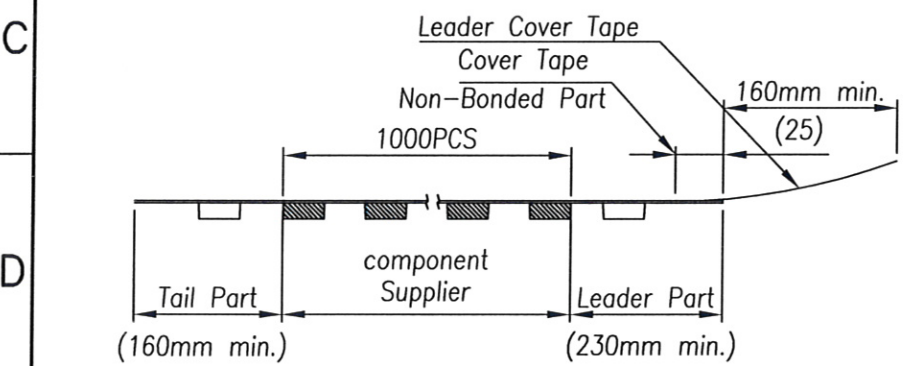
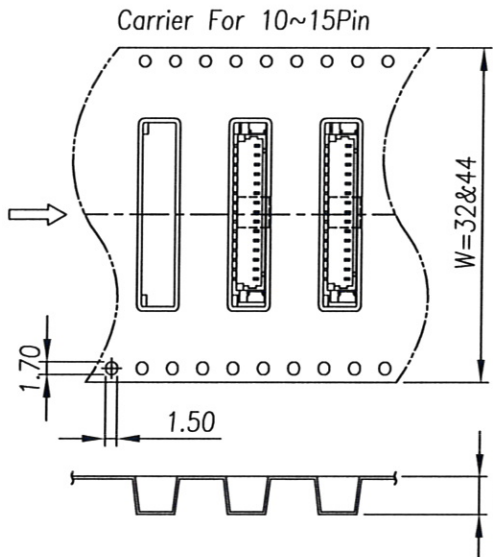
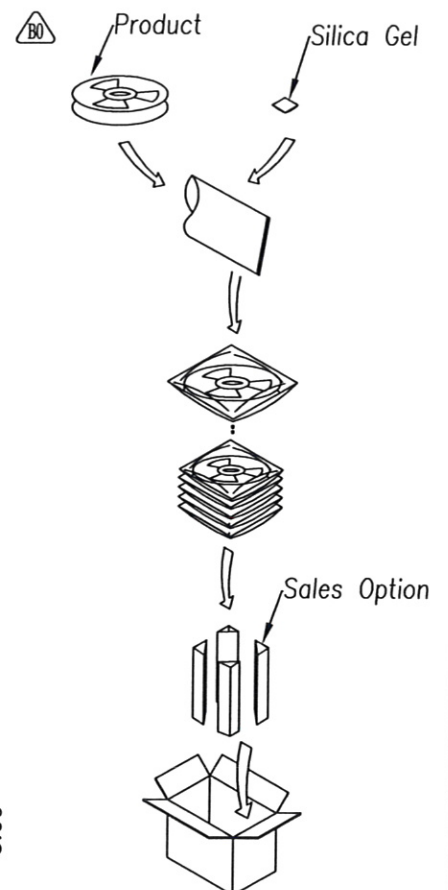
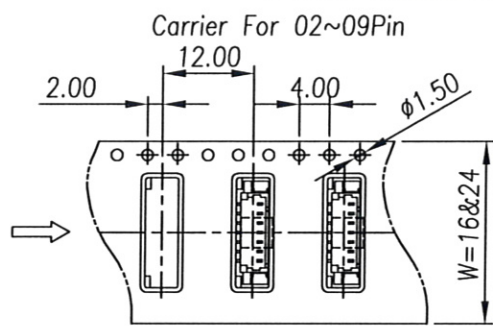
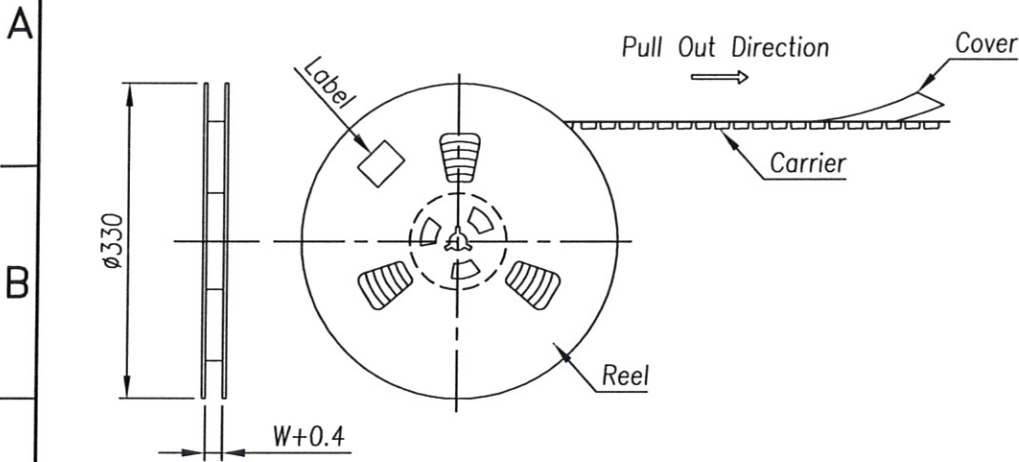

發行
104.8.28
文管中心

PIN NO.	W±0.30	PCS/REEL
02 ~ 03	16	1000
04 ~ 09	24	
10 ~ 13	32	
14 ~ 15	44	

Notes:
1. Material : PS
2. Part No.: AS07600XXXX01 & AS07600XXXX11

金上達科技股份有限公司
GOLDENSUNDA TECHNOLOGY CO.,LTD

TITLE: Wire To Board Wafer 1.25mm 180° SMT Single Row

TOLERANCE UNLESS OTHERWISE SPECIFIED	PROJ.	PART NO. AS07600XXXXX1		DWG NO. AS07600XXXXX1	
.x± 0.35	x.'± 2'	APR. C.F.Liao 20150828	UNITS: mm	CUSTOMER DRAWING	
.xx± 0.25	.x'± 1'	CHK: Abel 20150828	SIZE: A4	SCALE Free	SHEET 2 / 2
.xxx± 0.15	.xx'± 0.5'	DRA: Michelle 20150828	REV B1		