

1 2 3 4 5 6 7 8

REV	MODIFICATION	DATE	DRAW
A0	Release To PDR20130301	2013.11.14	Michelle

A

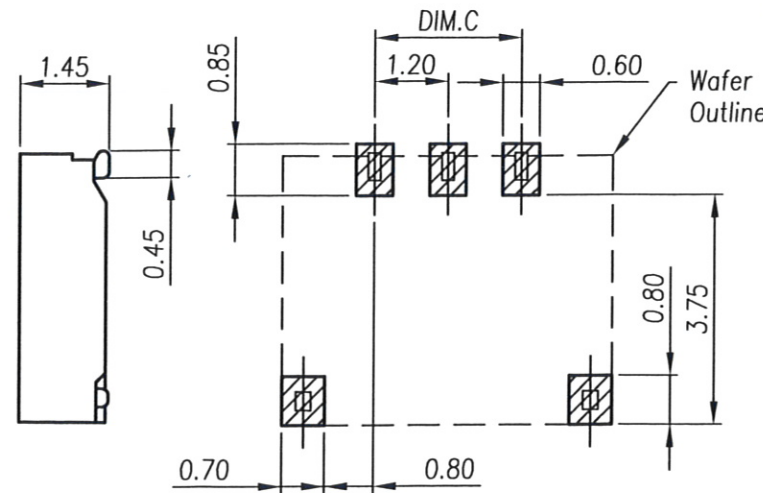
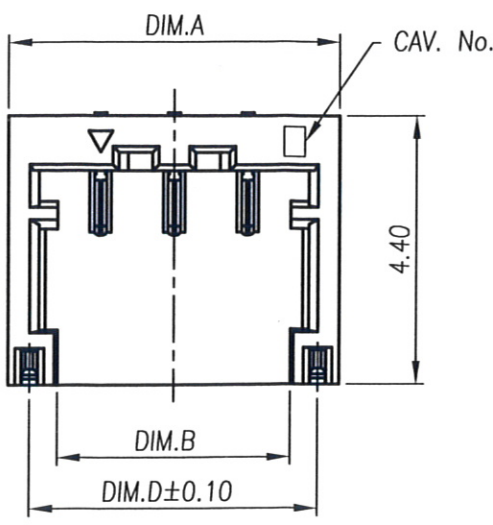

**RoHS Compliant**

**Specification**

- 1.Voltage Rating:50V AC/DC
- 2.Current Rating:2A AC/DC, AWG#28~30
- 3.Contact Resistance:10mΩ Max.
- 4.Insulation Resistance:100MΩ Min.
- 5.Dielectric Withstanding Voltage:500VAC/Minute
- 6.Operating Temperature:-55℃~+85℃

**Material:**

- 1.Housing:High Temperature Thermoplastic UL94V-0
- 2.Tab:Copper Alloy T=0.25mm
- 3.Contact:Copper Alloy T=0.20mm

**Finish:**

- 1.Housing:Black
- 2.Tab:Matte Plated Over Nickel
- 3.Contact:See P/N Option

Part No.: WT05M-30001- XX 0 X X

PIN \_\_\_\_\_  
 02~06PIN  
 Packing \_\_\_\_\_  
 2:Tube  
 3:T&R

Plated \_\_\_\_\_  
 3:Gold Flash Over Nickel.  
 4:Gold Plated 3u" On Contact Area.

B

C

D

E

F

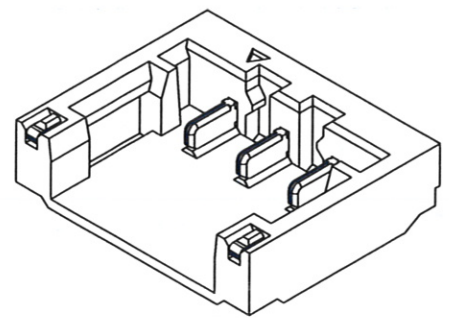
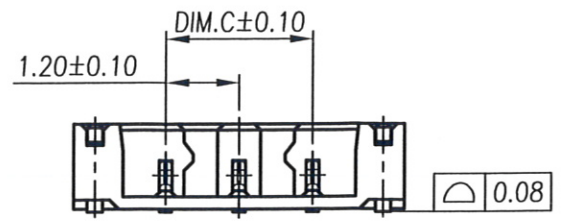

Pin	DIM.A	DIM.B	DIM.C	DIM.D
02	4.20	2.60	1.20	3.50
03	5.40	3.80	2.40	4.70
04	6.60	5.00	3.60	5.90
05	7.80	6.20	4.80	7.10
06	9.00	7.40	6.00	8.30

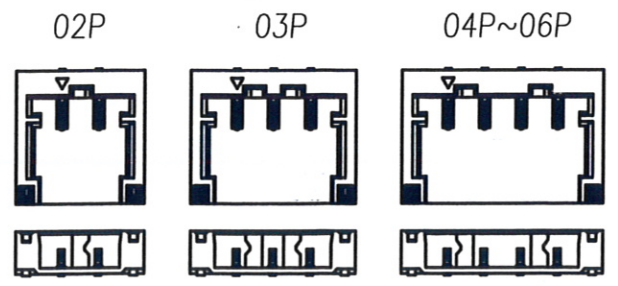



## 金上達科技股份有限公司

GOLDENSUND TECHNOLOGY CO.,LTD

TOLERANCE UNLESS OTHERWISE SPECIFIED		PROJ. 	TITLE: Wire To Board Wafer 1.20mm 90° SMT Single Row	
.x± 0.35	x:± 2'	APR. Jefferson 20131114	PART NO. WT05M-30001-XX0XX	DWG NO. WT05M-300-C-01
.xx± 0.25	.x'± 1'	CHK. Abel 20131114	UNITS: mm	CUSTOMER DRAWING
.xxx± 0.15	.xx'± 0.5'	DRA. Michelle 20131114	SIZE: <b>A4</b>	
		SHEET 1 / 1		REV A0

1 2 3 4 5 6 7 8

REV	MODIFICATION	DATE	DRAW
A0	Release To PDR20130301	2013.11.14	Michelle

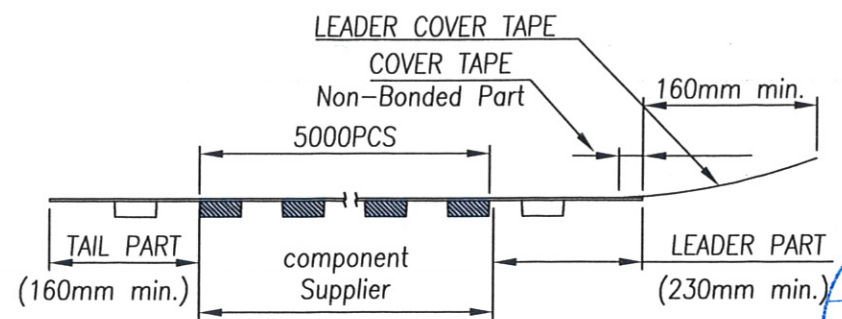
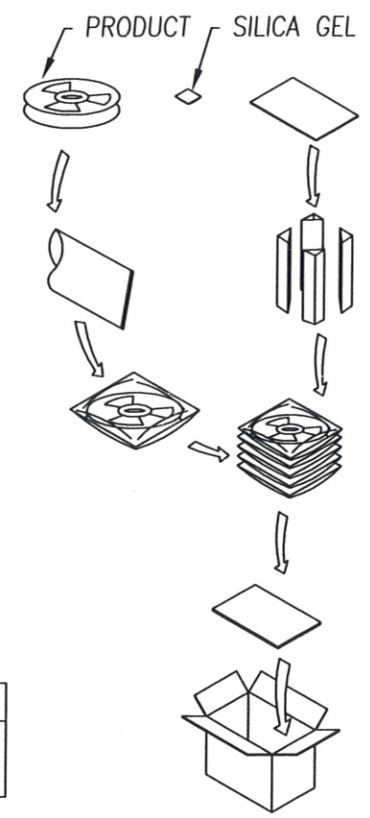
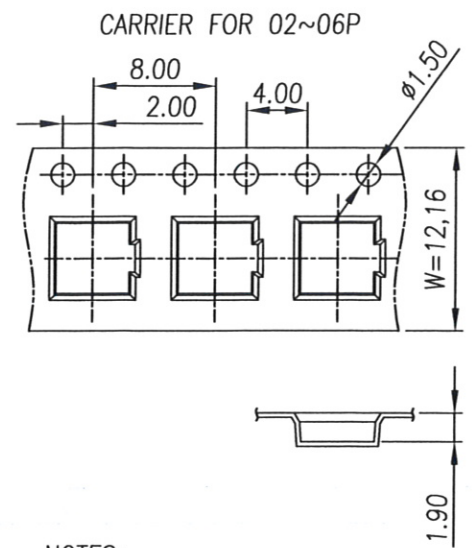
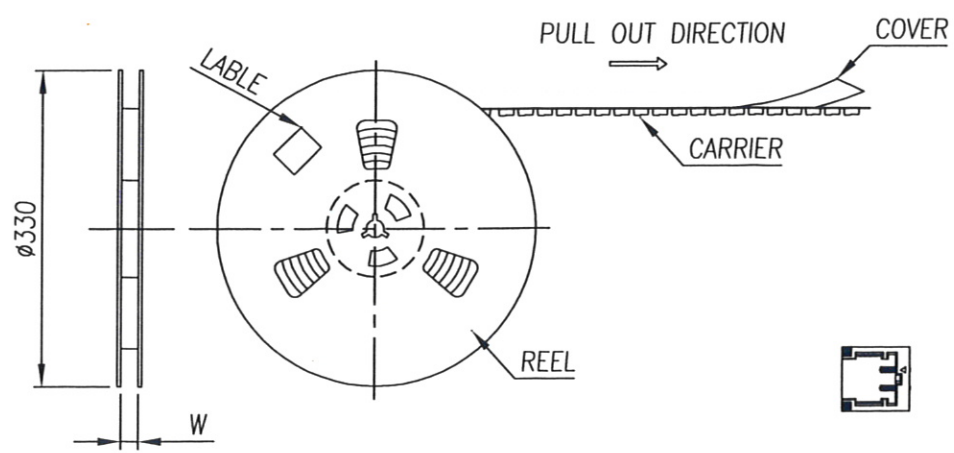

- NOTES:
1. Material : PS
  2. Part No.:WT05M-30001-XX03X

PIN NO.	W ±0.30	PCS / REEL
02	12	5000
03~06	16	

發行  
102.11.15  
文管中心

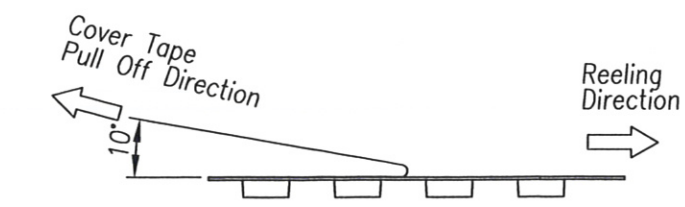

RoHS Compliant



## 金上達科技股份有限公司

GOLDENSUND TECHNOLOGY CO.,LTD

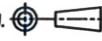
TOLERANCE UNLESS OTHERWISE SPECIFIED		PROJ. 	TITLE: Wire To Board Wafer 1.20mm 90° SMT	
.x± 0.35	x.± 2'	APR. Jefferson 20131114	PART NO. WT05M-30001-XX0XX	DWG NO. WT05M-300-C-01
.xx± 0.25	.x± 1'	CHK. Abel 20131114	UNITS: mm	<b>CUSTOMER DRAWING</b>
.xxx± 0.15	.xx± 0.5'	DRA. Michelle 20131114	SIZE: <b>A4</b>	SCALE FREE SHEET 2 / 2 REV A0