

1 2 3 4 5 6 7 8

 **RoHS Compliant**

REV	MODIFICATION	DATE	DRAW
A0	Release To Production	2008.12.31	Abel
A1	Release To ECN Drawing	2010.05.14	AJ
A2	Release To ECN20130313	2013.03.29	Seven

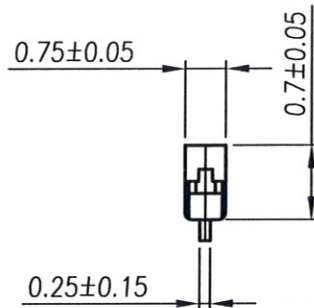
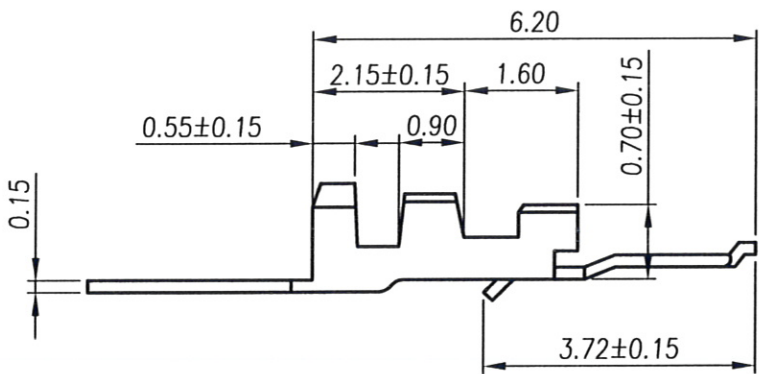
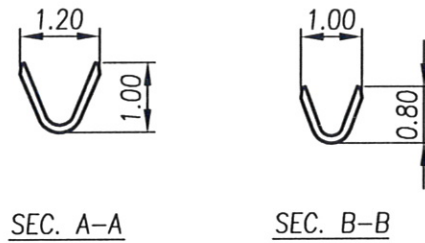
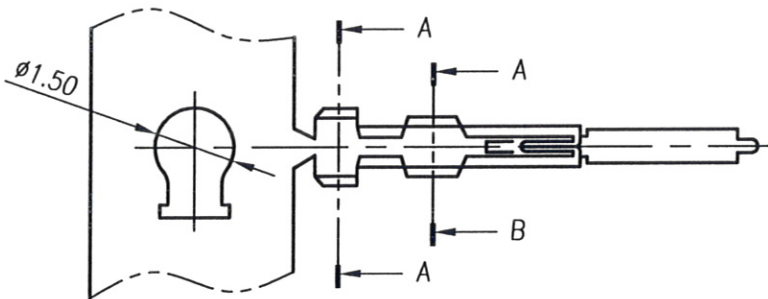

Specifications & Ordering Information:

Part No	Thickness	Material	Wire Range
CC0880200P3AC	0.15mm	Phosphor Bronze	AWG #28~32
Insulation O.D.	Finish	Qty/reel	Use With
0.80mm max.	Gold Flash	15,000PCS	BC08800XX31BA



## 金上達科技股份有限公司

GOLDENSUND TECHNOLOGY CO.,LTD

TOLERANCE UNLESS OTHERWISE SPECIFIED		PROJ. 	TITLE: Wire To Board Terminal 1.00mm Female		
.x± 0.35	x.*± 2'	APR. Jay 20130329	PART NO. CC0880200P3AC	DWG NO. CC0880200P3AC	
.xx± 0.25	.x.*± 1'	CHK. Michelle 20130329	UNITS: mm	<b>CUSTOMER DRAWING</b>	
.xxx± 0.15	.xx.*± 0.5'	DRA. Seven 20130329	SIZE: <b>A4</b>	SCALE 10:1	SHEET 1 / 1 REV A2 V

1 2 3 4 5 6 7 8