

RECOMMENDED P.C.B LAYOUT

REV	MODIFICATION	DATE	DRAW
A1	增加包裝	2010.06.08	AJ
A2	Release To ECN20130814	2013.09.11	Michelle
A3	Release To ECN20150609	2015.06.22	Michelle

Specification

- Current Rating: 1A
- Insulation Resistance: 1000MΩ Min. At DC 500V
- Dielectric Withstanding Voltage: AC800V/Minute
- Operating Temperature: -55°C ~ +105°C

Material:

- Housing: High Temperature Thermoplastic UL94V-0
- Contact Pin: Copper Alloy SQ Pin 0.50mm
- Cap: High Temperature Thermoplastic UL94V-0

Finish:

- Housing: Black
- Contact Pin: Gold Flash Over Nickel
- Cap: Black

Part No.: ES07326 XX 4 3 X E

No. Of Pin: 08~50

Packing: Y: Tray With Cap, 0: T&R With Cap (380PCS)

Housing Material: 4: NY6T UL94V-0 Black

Plating: 3: Gold Flash Over Nickel

PIN	DIM.A	DIM.B	DIM.C	PIN	DIM.A	DIM.B	DIM.C
08	6.00	8.85	10.65	26	24.00	26.85	28.65
10	8.00	10.85	12.65	30	28.00	30.85	32.65
12	10.00	12.85	14.65	34	32.00	34.85	36.65
14	12.00	14.85	16.65	40	38.00	40.85	42.65
16	14.00	16.85	18.65	44	42.00	44.85	46.65
20	18.00	20.85	22.65	50	48.00	50.85	52.65
24	22.00	24.85	26.65				





## 金上達科技股份有限公司

GOLDENSUNDA TECHNOLOGY CO., LTD

TOLERANCE UNLESS OTHERWISE SPECIFIED		PROJ. 	TITLE: Box Header 2.00mm 180' H=6.40 SMT Dual Row	
.x ± 0.35	x' ± 2'	APR. C.F. Liao 20150622	PART NO. ES07326XX43XE	DWG NO. ES07326XX43XE
.xx ± 0.25	.x' ± 1'	CHK. Abel 20150622	UNITS: mm	<b>CUSTOMER DRAWING</b>
.xxx ± 0.15	.xx' ± 0.5'	DRW. Michelle 20150622	SIZE: <b>A4</b>	SCALE: 4:1
		SHEET 1 / 2		REV: A3

REV	MODIFICATION	DATE	DRAW
A1	增加包裝	2010.06.08	AJ
A2	Release To ECN20130814	2013.09.11	Michelle
A3	Release To ECN20150609	2015.06.22	Michelle

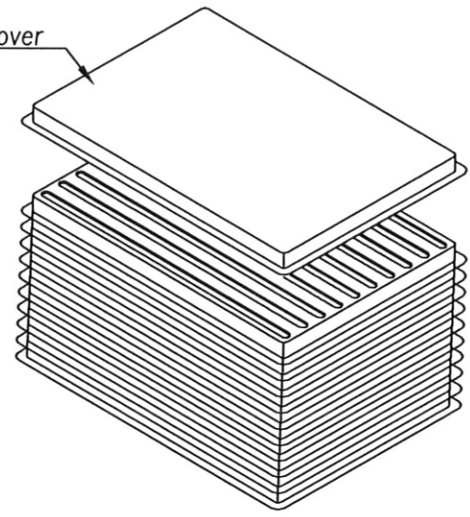

Load Into Carton After Sealing Tray.

PIN	Q'TY	PIN	Q'TY
2x4P (08)	624	2x13P(26)	216
2x5P (10)	504	2x15P(30)	192
2x6P (12)	432	2x17P(34)	168
2x7P (14)	384	2x20P(40)	144
2x8P (16)	336	2x22P(44)	120
2x10P(20)	288	2x25P(50)	120
2x12P(24)	240		

A3

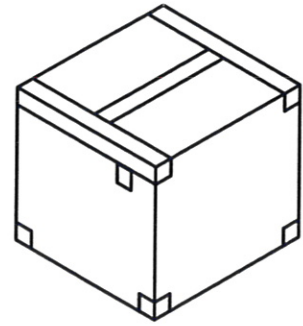
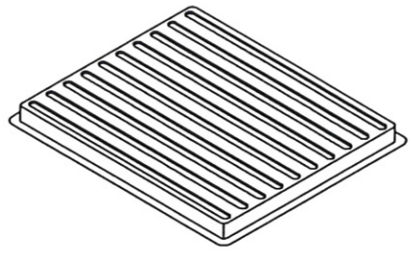
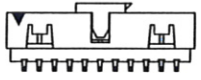

CLOSE CARTON WITH TAPE.

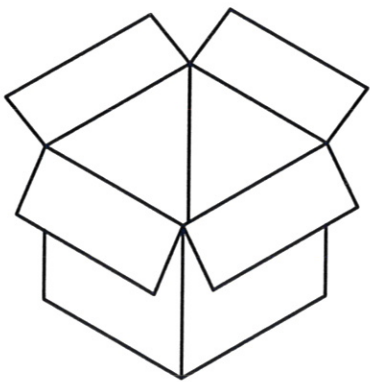



## 金上達科技股份有限公司

**GOLDENSUNDA TECHNOLOGY CO.,LTD**

TOLERANCE UNLESS OTHERWISE SPECIFIED		PROJ. 	TITLE: Box Header 2.00mm 180' H=6.40 SMT Dual Row	
.x± 0.35	x.*± 2'	APR. C.F. Liao 20150622	PART NO. ES07326XX43XE	DWG NO. ES07326XX43XE
.xx± 0.25	.x*± 1'	CHK. Abel 20150622	UNITS: mm	CUSTOMER DRAWING
.xxx± 0.15	.xx*± 0.5'	DRA. Michelle 20150622	SIZE: <b>A4</b>	SCALE Free

SHEET 2 / 2	REV A3	V
-------------	--------	---