

| REV | MODIFICATION | DATE | DRAW |
|-----|------------------------|------------|----------|
| A3 | Release To ECN20120907 | 2012.09.14 | Michelle |
| A4 | Release To ECN20140408 | 2014.04.29 | Michelle |
| A5 | Release To ECN20150313 | 2015.03.25 | Michelle |

RoHS Compliant

- Specification
- 1.Current Rating:0.4A AC/DC ΔA
 - 2.Voltage Rating:50V AC/DC
 - 3.Contact Resistance:20m Ω Max.
 - 4.Insulation Resistance:500M Ω Min. At DC 500V ΔA
 - 5.Dielectric Withstanding Voltage:AC200V/Minute ΔA
 - 6.Operating Temperature:-25°C~+85°C

- Material:
- 1.Housing:High-Temp. Thermoplastic UL94V-0
 - 2.Slider:High-Temp. Thermoplastic UL94V-0
 - 3.Solder:Copper Alloy T=0.20mm
 - 4.Contact Pin:Copper Alloy T=0.20mm

- Finish:
- 1.Housing:Nature
 - 2.Slider:Black ΔA
 - 3.Solder:Matte Tin Plated Over Nickel ΔA
 - 4.Contact Pin:See P/N Option

Part No.: DS00104 XX 3 X X 2

- ΔA Number of Pin: 04~60
- ΔA Packing: 1:T&R, 4:Tube
- ΔA ΔA Housing/Slider Material: 3:LCP UL94V-0 Nature, LCP UL94V-0 Black
- ΔA 1:Matte Tin Plated Over Nickel, 3:Gold Flash Plated Over Nickel

發行
104.3.25
文管中心

金上達科技股份有限公司
GOLDENSUNDA TECHNOLOGY CO.,LTD

| | | | |
|--------------------------------------|------------|--|------------------------|
| TOLERANCE UNLESS OTHERWISE SPECIFIED | PROJ. | TITLE: FPC/FFC 0.50mm 90° H=2.00 SMT ZIF Upper Contact SN Type | |
| .x± 0.35 | x*± 2' | APR. C.F.Liao 20150325 | PART NO. DS00104XX3XX2 |
| .xx± 0.25 | .x*± 1' | CHK. Abel 20150325 | DWG NO. DS00104XX3XX2 |
| .xxx± 0.15 | .xx*± 0.5' | DRA. Michelle 20150325 | UNITS: mm |
| | | SIZE: A4 | SCALE 6:1 |
| | | SHEET 1 / 2 | REV A5 |
| | | | V |

CUSTOMER DRAWING

RoHS Compliant



| REV | MODIFICATION | DATE | DRAW |
|-----|------------------------|------------|----------|
| A3 | Release To ECN20120907 | 2012.09.14 | Michelle |
| A4 | Release To ECN20140408 | 2014.04.29 | Michelle |
| A5 | Release To ECN20150313 | 2015.03.25 | Michelle |

★ Have Produce Pin Number

| PIN | DIM.A | DIM.B | DIM.C | DIM.D | DIM.E | PIN | DIM.A | DIM.B | DIM.C | DIM.D | DIM.E | PIN | DIM.A | DIM.B | DIM.C | DIM.D | DIM.E |
|-----|-------|-------|-------|-------|-------|-------|-------|-------|-------|-------|-------|-------|-------|-------|-------|-------|-------|
| ★04 | 7.60 | 6.50 | 1.50 | 2.60 | 4.40 | ★23 | 17.10 | 16.00 | 11.00 | 12.10 | 4.40 | ★42 | 26.60 | 25.50 | 20.50 | 21.60 | 4.90 |
| ★05 | 8.10 | 7.00 | 2.00 | 3.10 | | ★24 | 17.60 | 16.50 | 11.50 | 12.60 | | 43 | 27.10 | 26.00 | 21.00 | 22.10 | |
| ★06 | 8.60 | 7.50 | 2.50 | 3.60 | | ★25 | 18.10 | 17.00 | 12.00 | 13.10 | | ★44 | 27.60 | 26.50 | 21.50 | 22.60 | |
| ★07 | 9.10 | 8.00 | 3.00 | 4.10 | | ★26 | 18.60 | 17.50 | 12.50 | 13.60 | | ★45 | 28.10 | 27.00 | 22.00 | 23.10 | |
| ★08 | 9.60 | 8.50 | 3.50 | 4.60 | | ★27 | 19.10 | 18.00 | 13.00 | 14.10 | | 46 | 28.60 | 27.50 | 22.50 | 23.60 | |
| ★09 | 10.10 | 9.00 | 4.00 | 5.10 | | ★28 | 19.60 | 18.50 | 13.50 | 14.60 | | 47 | 29.10 | 28.00 | 23.00 | 24.10 | |
| ★10 | 10.60 | 9.50 | 4.50 | 5.60 | | ★29 | 20.10 | 19.00 | 14.00 | 15.10 | | ★48 | 29.60 | 28.50 | 23.50 | 24.60 | |
| ★11 | 11.10 | 10.00 | 5.00 | 6.10 | | ★30 | 20.60 | 19.50 | 14.50 | 15.60 | | ★49 | 30.10 | 29.00 | 24.00 | 25.10 | |
| ★12 | 11.60 | 10.50 | 5.50 | 6.60 | | ★31 | 21.10 | 20.00 | 15.00 | 16.10 | | ★50 | 30.60 | 29.50 | 24.50 | 25.60 | |
| ★13 | 12.10 | 11.00 | 6.00 | 7.10 | | ★32 | 21.60 | 20.50 | 15.50 | 16.60 | | ★51 | 31.10 | 30.00 | 25.00 | 26.10 | |
| ★14 | 12.60 | 11.50 | 6.50 | 7.60 | ★33 | 22.10 | 21.00 | 16.00 | 17.10 | 52 | 31.60 | 30.50 | 25.50 | 26.60 | | | |
| ★15 | 13.10 | 12.00 | 7.00 | 8.10 | ★34 | 22.60 | 21.50 | 16.50 | 17.60 | ★53 | 32.10 | 31.00 | 26.00 | 27.10 | | | |
| ★16 | 13.60 | 12.50 | 7.50 | 8.60 | ★35 | 23.10 | 22.00 | 17.00 | 18.10 | ★54 | 32.60 | 31.50 | 26.50 | 27.60 | | | |
| ★17 | 14.10 | 13.00 | 8.00 | 9.10 | ★36 | 23.60 | 22.50 | 17.50 | 18.60 | ★55 | 33.10 | 32.00 | 27.00 | 28.10 | | | |
| ★18 | 14.60 | 13.50 | 8.50 | 9.60 | ★37 | 24.10 | 23.00 | 18.00 | 19.10 | 56 | 33.60 | 32.50 | 27.50 | 28.60 | | | |
| ★19 | 15.10 | 14.00 | 9.00 | 10.10 | ★38 | 24.60 | 23.50 | 18.50 | 19.60 | ★57 | 34.10 | 33.00 | 28.00 | 29.10 | | | |
| ★20 | 15.60 | 14.50 | 9.50 | 10.60 | 39 | 25.10 | 24.00 | 19.00 | 20.10 | 58 | 34.60 | 33.50 | 28.50 | 29.60 | | | |
| ★21 | 16.10 | 15.00 | 10.00 | 11.10 | ★40 | 25.60 | 24.50 | 19.50 | 20.60 | 59 | 35.10 | 34.00 | 29.00 | 30.10 | | | |
| ★22 | 16.60 | 15.50 | 10.50 | 11.60 | ★41 | 26.10 | 25.00 | 20.00 | 21.10 | ★60 | 35.60 | 34.50 | 29.50 | 30.60 | | | |

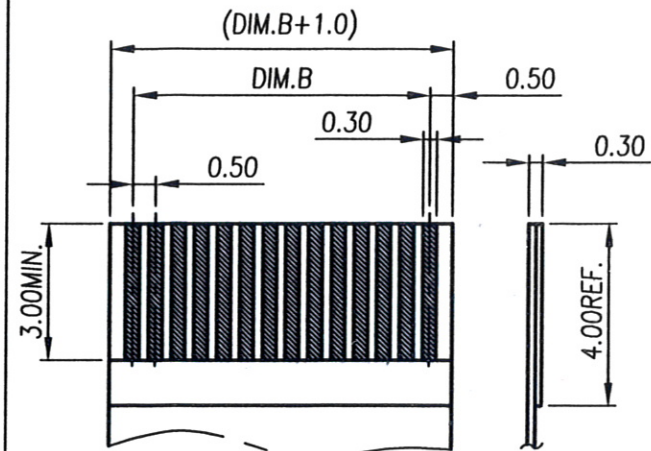

RECOMMENDED APPLICABLE FFC



| | | | | |
|--------------------------------------|-------------|----------------------------|---|--------------------------|
| TOLERANCE UNLESS OTHERWISE SPECIFIED | | PROJ. | TITLE: FPC/FFC 0.50mm 90° H=2.00 SMT ZIF Upper Contact SN Type | |
| .x± 0.35 | x.*± 2' | APR. C.F. Liao 20150325 | PART NO. DS00104XX3XX2 | DWG NO. DS00104XX3XX2 |
| .xx± 0.25 | .x.*± 1' | CHK. Abel 20150325 | UNITS: mm | CUSTOMER DRAWING |
| .xxx± 0.15 | .xx.*± 0.5' | DRA. Michelle 20150325 | SIZE: A4 | SCALE 6:1 |
| | | | SHEET 2 / 2 | REV A5 V |