

RoHS Compliant

發行
104.3.25
文管中心

REV	MODIFICATION	DATE	DRAW
A3	Release To ECN20120514	2012.06.22	Seven
A4	Release To ECN20120801	2012.08.01	Michelle
A5	Release To ECN20150313	2015.03.25	Michelle

- Specification
- 1.Current Rating:0.4A AC/DC
 - 2.Voltage Rating:50V AC/DC
 - 3.Contact Resistance:20mΩ Maximum
 - 4.Insulation Resistance:500MΩ Minimum
 - 5.Dielectric Withstanding Voltage:AC200V/Minute
 - 6.Operating Temperature:-25°C~+85°C

- Material:
- 1.Housing:High Temperature Thermoplastic UL94V-0
 - 2.Contact Pin:Copper Alloy T=0.20mm
 - 3.Slider:High-Temp. Thermoplastic UL94V-0
 - 4.Fitting Nail:Copper Alloy T=0.20mm

- Finish:
- 1.Housing:See P/N Option
 - 2.Contact Pin:Matte Tin Over Nickel
 - 3.Slider:See P/N Option
 - 4.Fitting Nail:Matte Tin Plated Over Nickel

Part No.: DS00108 XX X 2 X 2

No. Of Pin
04~60

Packing
1:T&R
4:Tube

- △△ Housing/Slider Material
- 7:LCP UL94V-0 Black
 - PPS UL94V-0 Nature
 - 8:NY6T UL94V-0 Nature
 - PPS UL94V-0 Black
- Plating
- 2:Matte Tin Plated Over Nickel

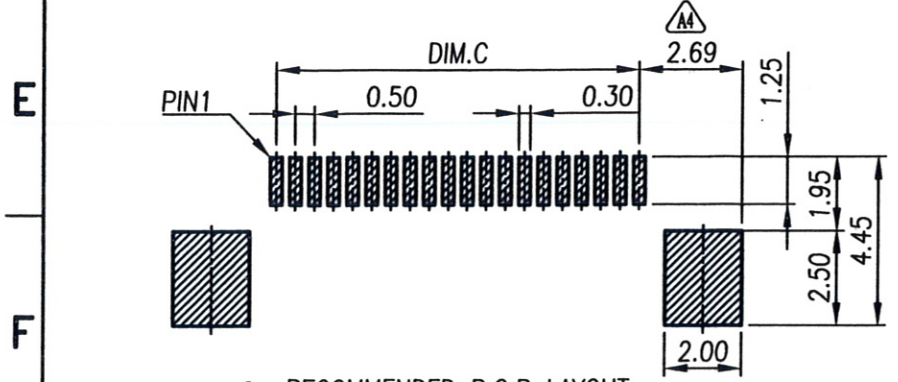
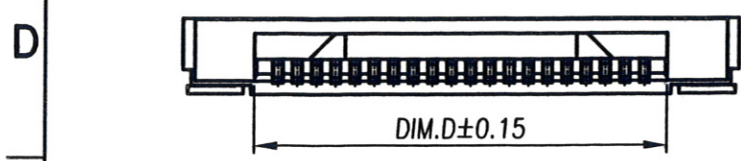
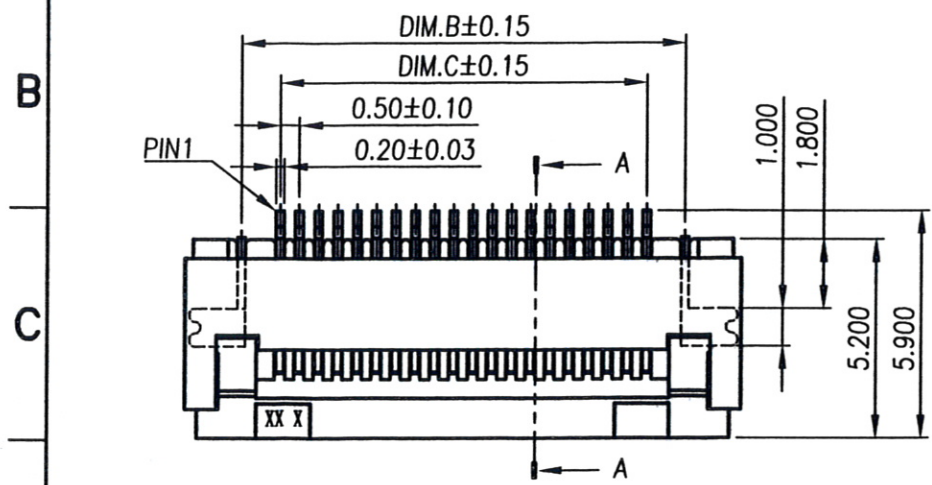
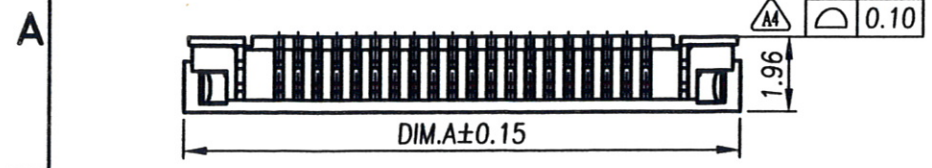

△△ RECOMMENDED P.C.B LAYOUT

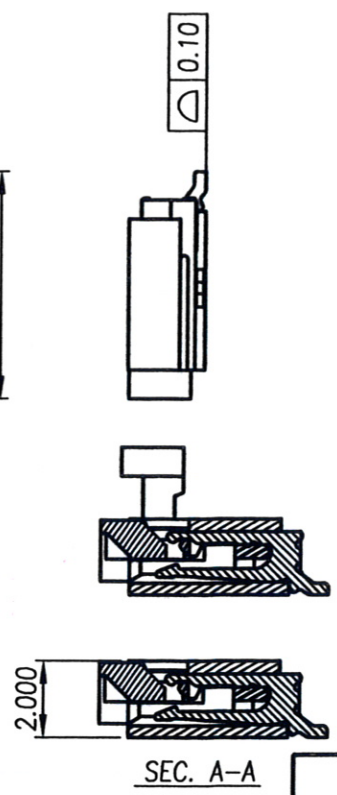

金上達科技股份有限公司
GOLDENSUNDA TECHNOLOGY CO.,LTD

TOLERANCE UNLESS OTHERWISE SPECIFIED		PROJ.	TITLE: FPC/FFC 0.50mm 90° H=2.00 SMT ZIF Press Bottom Contact	
.x± 0.35	x.'± 2'	APR. C.F.Liao 20150325	PART NO. DS00108XXX2X2	DWG NO. DS00108XXX2X2
.xx± 0.25	.x'± 1'	CHK. Abel 20150325	UNITS: mm	CUSTOMER DRAWING
.xxx± 0.15	.xx'± 0.5'	DRA. Michelle 20150325	SIZE: A4	
		SCALE Free		SHEET 1 / 3
		REV A5		V

RoHS Compliant



REV	MODIFICATION	DATE	DRAW
A3	Release To ECN20120514	2012.06.22	Seven
A4	Release To ECN20120801	2012.08.01	Michelle
A5	Release To ECN20150313	2015.03.25	Michelle

PIN	Dimension				PIN	Dimension				PIN	Dimension			
	A	B	C	D		A	B	C	D		A	B	C	D
04	6.40	3.50	1.50	2.60	23	15.90	13.00	11.00	12.10	42	25.40	22.50	20.50	21.60
05	6.90	4.00	2.00	3.10	24	16.40	13.50	11.50	12.60	43	25.90	23.00	21.00	22.10
06	7.40	4.50	2.50	3.60	25	16.90	14.00	12.00	13.10	44	26.40	23.50	21.50	22.60
07	7.90	5.00	3.00	4.10	26	17.40	14.50	12.50	13.60	45	26.90	24.00	22.00	23.10
08	8.40	5.50	3.50	4.60	27	17.90	15.00	13.00	14.10	46	27.40	24.50	22.50	23.60
09	8.90	6.00	4.00	5.10	28	18.40	15.50	13.50	14.60	47	27.90	25.00	23.00	24.10
10	9.40	6.50	4.50	5.60	29	18.90	16.00	14.00	15.10	48	28.40	25.50	23.50	24.60
11	9.90	7.00	5.00	6.10	30	19.40	16.50	14.50	15.60	49	28.90	26.00	24.00	25.10
12	10.40	7.50	5.50	6.60	31	19.90	17.00	15.00	16.10	50	29.40	26.50	24.50	25.60
13	10.90	8.00	6.00	7.10	32	20.40	17.50	15.50	16.60	51	29.90	27.00	25.00	26.10
14	11.40	8.50	6.50	7.60	33	20.90	18.00	16.00	17.10	52	30.40	27.50	25.50	26.60
15	11.90	9.00	7.00	8.10	34	21.40	18.50	16.50	17.60	53	30.90	28.00	26.00	27.10
16	12.40	9.50	7.50	8.60	35	21.90	19.00	17.00	18.10	54	31.40	28.50	26.50	27.60
17	12.90	10.00	8.00	9.10	36	22.40	19.50	17.50	18.60	55	31.90	29.00	27.00	28.10
18	13.40	10.50	8.50	9.60	37	22.90	20.00	18.00	19.10	56	32.40	29.50	27.50	28.60
19	13.90	11.00	9.00	10.10	38	23.40	20.50	18.50	19.60	57	32.90	30.00	28.00	29.10
20	14.40	11.50	9.50	10.60	39	23.90	21.00	19.00	20.10	58	33.40	30.50	28.50	29.60
21	14.90	12.00	10.00	11.10	40	24.40	21.50	19.50	20.60	59	33.90	31.00	29.00	30.10
22	15.40	12.50	10.50	11.60	41	24.90	22.00	20.00	21.10	60	34.40	31.50	29.50	30.60

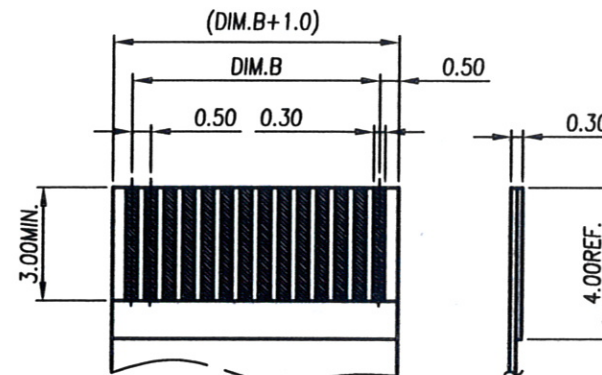

RECOMMENDED APPLICABLE FFC



TOLERANCE UNLESS OTHERWISE SPECIFIED		PROJ.	TITLE: FPC/FFC 0.50mm 90° H=2.00 SMT ZIF Press Bottom Contact		
			APR. C.F.Liao 20150325	PART NO. DS00108XXX2X2	DWG NO. DS00108XXX2X2
.x± 0.35	x.'± 2'	CHK. Abel 20150325	UNITS: mm	CUSTOMER DRAWING	
.xx± 0.25	.x'± 1'	DRA. Michelle 20150325	SIZE: A4	SCALE Free	SHEET 2 / 3
.xxx± 0.15	.xx'± 0.5'			REV A5	V

RoHS Compliant



REV	MODIFICATION	DATE	DRAW
A3	Release To ECN20120514	2012.06.22	Seven
A4	Release To ECN20120801	2012.08.01	Michelle
A5	Release To ECN20150313	2015.03.25	Michelle

A

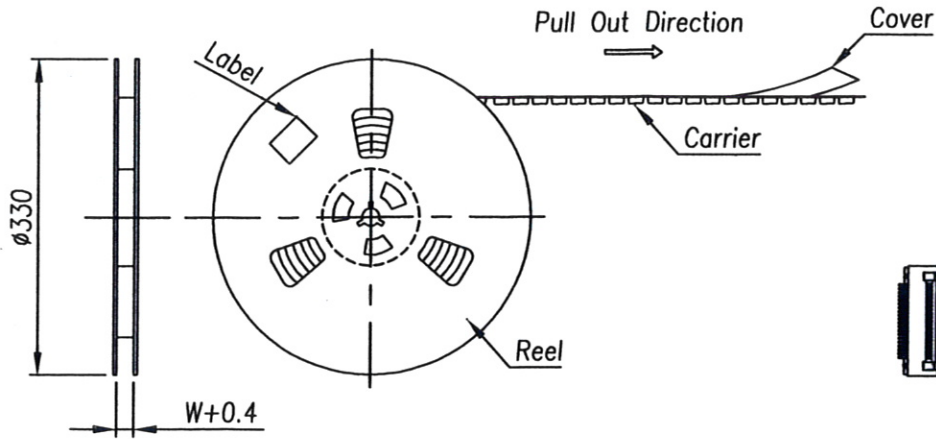

B

C

D

E

F

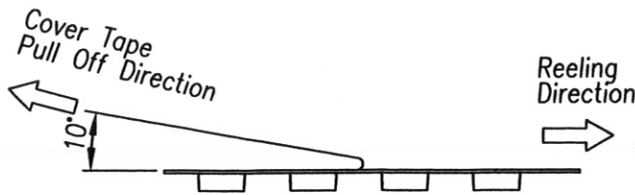
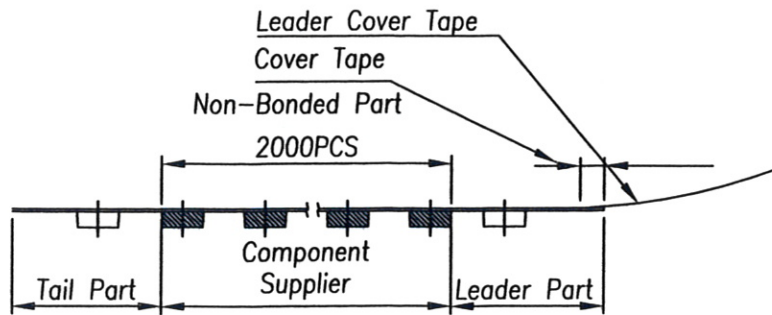

NOTES:

1. Material : PS
2. Part No.: DS00108XXX212

PIN NO.	W ±0.30	PCS / REEL
04 ~ 24	24	2000
25 ~ 30	32	
31 ~ 50	44	
51 ~ 60	56	

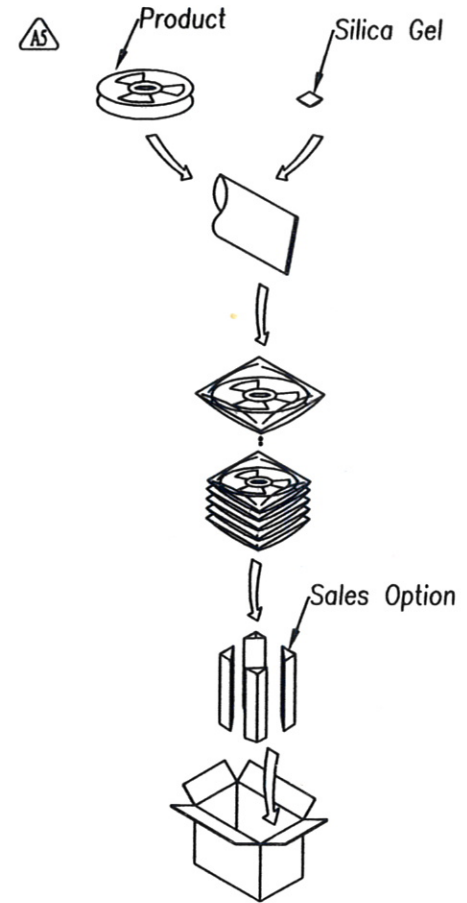
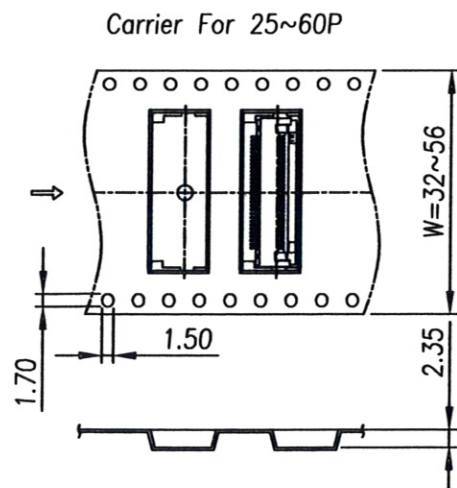
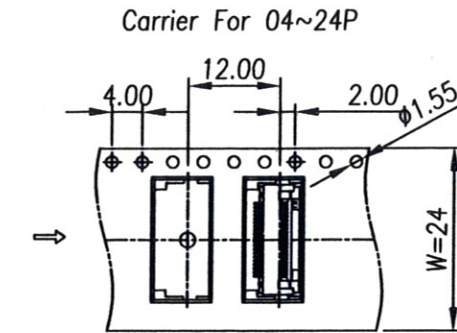



金上達科技股份有限公司

GOLDENSUNDA TECHNOLOGY CO.,LTD

TOLERANCE UNLESS OTHERWISE SPECIFIED		PROJ. APR. C.F.Liao 20150325	TITLE: FPC/FFC 0.50mm 90° H=2.00 SMT ZIF Press Bottom Contact	
.x± 0.35	.x'± 2'	CHK. Abel 20150325	PART NO. DS00108XXX2X2	DWG NO. DS00108XXX2X2
.xx± 0.25	.x'± 1'		UNITS: mm	CUSTOMER DRAWING
.xxx± 0.15	.xx'± 0.5'	DRA. Michelle 20150325	SIZE: A4	SCALE Free
			SHEET 3 / 3	REV A5

1 2 3 4 5 6 7 8