

**RoHS Compliant**

REV	MODIFICATION	DATE	DRAW
A0	Release To Production	2010.01.05	AJ
A1	Release To ECN20111008	2011.10.24	Seven
A2	Release To ECN20130502	2013.05.03	Seven

**Specification**

- 1.Current Rating:1.5A AC/DC
- 2.Voltage Rating:250V AC/DC
- 3.Contact Resistance:30mΩ Max.
- 4.Insulation Resistance:1000MΩ Min.At DC 500V
- 5.Dielectric Withstanding Voltage:500 VAC/Minute
- 6.Insertion Force:35N Max.
- 7.Extraction Force:10N Min.
- 8.Solderability:245±5°C For 5±0.5 sec.

**Material:**

- 1.Housing: Thermoplastic UL94V-0
- 2.Contact Pin:Copper Alloy T=0.25mm
- 3.Shell:K7 T=0.30mm

**Finish:**

- 1.Housing:See P/N Option
- 2.Contact Pin:See P/N Option
- 3.Shell:Nickel Plated

Part No.: FDE1101 04 X 4 Y 6  
 Number Of Pin 04      Packing Y:TRAY

Housing Material      Plating  
 4:PBT UL94V-0 Black      4:Gold Plated On Contact Area  
 6:PBT UL94V-0 White      Sn Plated On Solder tails Area.  
    Nickel Under Plated Over All.

**金上達科技股份有限公司**  
**GOLDENSUNDA TECHNOLOGY CO.,LTD**

TOLERANCE UNLESS OTHERWISE SPECIFIED		PROJ.	TITLE: USB A Female 90° 4Pin DIP		
.x± 0.35	x:± 2'	APR. Jay 20130503	PART NO. FDE110104X4Y6	DWG NO. FDE110104X4Y6	
.xx± 0.25	.x:± 1'	CHK. Michelle 20130503	UNITS: mm	CUSTOMER DRAWING	
.xxx± 0.15	.xx:± 0.5'	DRA. Seven 20130503	SIZE: A4	SCALE 2:1	SHEET 1 / 2
			REV A2	V	

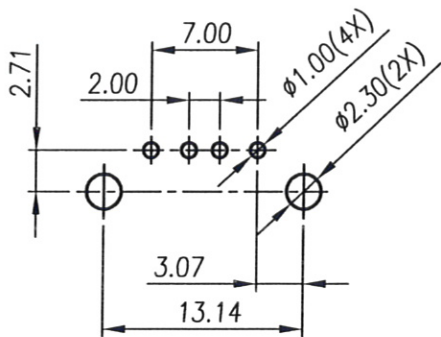

**RECOMMENDED PCB LAYOUT**  
 (TOLERANCE±0.05)

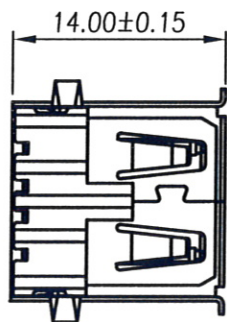
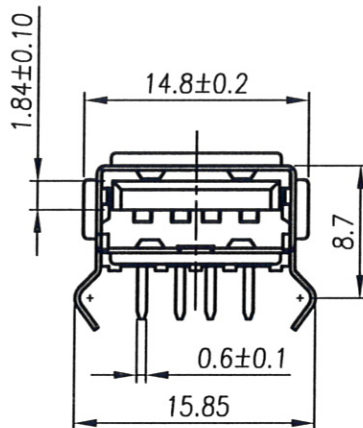
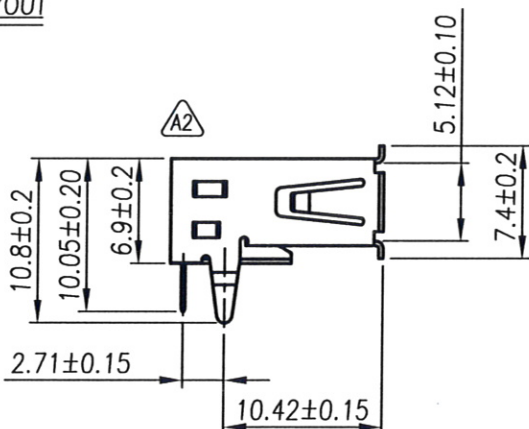
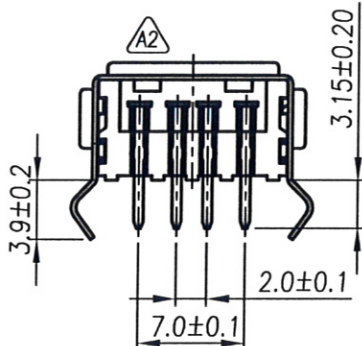
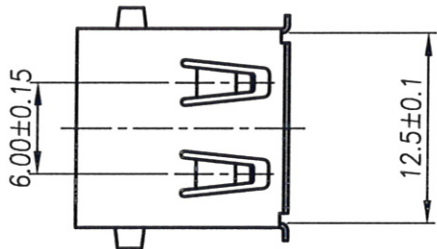

RoHS Compliant

REV	MODIFICATION	DATE	DRAW
A0	Release To Production	2010.01.05	AJ
A1	Release To ECN20111008	2011.10.24	Seven
A2	Release To ECN20130502	2013.05.03	Seven

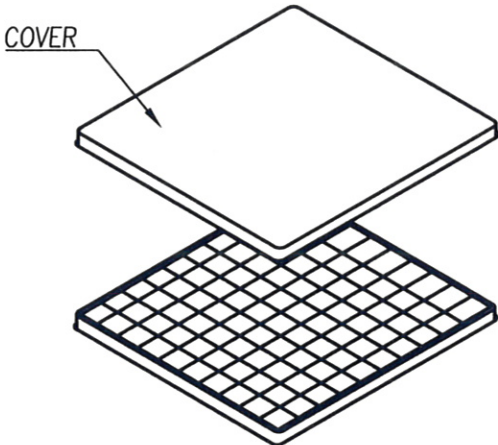
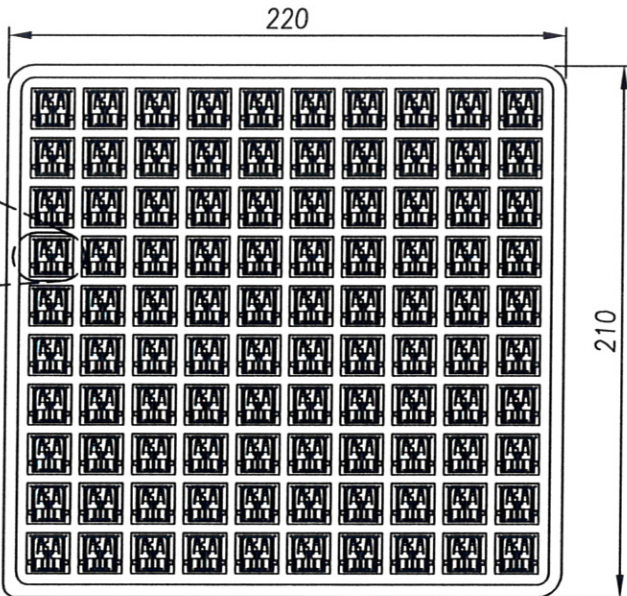

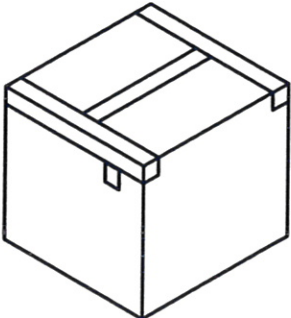

1 TRAY=100PCS

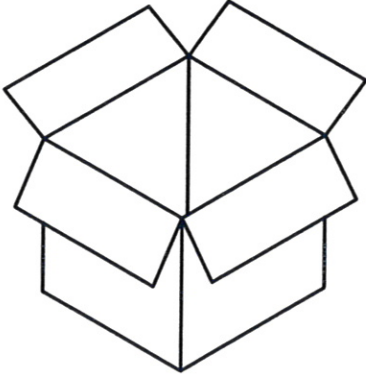

CLOSE CARTON WITH TAPE.



PUT ONE COVER ON THE PRODUCT TRAY

 <b>金上達科技股份有限公司</b> <b>GOLDENSUNDA TECHNOLOGY CO.,LTD</b>		TITLE: USB A Female 90° 4Pin DIP					
		TOLERANCE UNLESS OTHERWISE SPECIFIED .x± 0.35    x.± 2' .xx± 0.25    .x.± 1' .xxx± 0.15    .xx.± 0.5'		PROJ.  APR. Joy 20130503 CHK. Michelle 20130503 DRA. Seven 20130503		PART NO. FDE110104X4Y6 UNITS: mm SIZE: <b>A4</b>	